

**FERO-Z 24**

---

**OPERATOR'S MANUAL**

**TELESCOPE SIGHT, RIFLE  
4X MANIFICATION**

**NATO STOCK NO.: 1240-12-197-5192**

**HENSOLDT WETZLAR**

**SEPTEMBER 1985**

---

# Operating Instructions for Telescope Sight FERO-Z 24

Date: September 1985

## Table of Contents

<b>1</b>	<b>Description of Unit</b>	<b>Page</b>
1.1	Designation	11
1.2	Purpose	11
1.3	Scope of Supply	11
1.4	Technical Data	13
1.5	Construction	14
<b>2</b>	<b>Operation</b>	<b>15</b>
2.1	Transport	15
2.2	Operating Elements	15
2.3.	Putting Telescope Sight into Operation and Boresighting	15
<b>3</b>	<b>Maintenance</b>	<b>16</b>

## 1 Description of Unit

- 1.1 Designation:** Telescope sight FERO-Z 24
- 1.1.1 Drwg. No.: 330148-0000.000
- 1.1.2 NATO Stock No. (set): 1240-12-196-6470
- 1.1.3 Designation of stock item: TELESCOPE SIGHT, RIFLE,  
4x magnification, with accessories
- 1.1.4 Developing firm: M. HENSOLDT & SOHNE WETZLAR  
Optische Werke AG
- 1.1.5 Manufacturing firm: M. HENSOLDT & SOHNE WETZLAR  
Optische Werke AG
- 1.2 Purpose**
- The telescope sight is intended for use with the G3 rifle. It serves the rifleman for targeting and aiming and enables him to observe the enemy and the effect on the target even at a greater distance. The max. adjustable distance is 600 m. After consideration of the various ballistic data the telescope sight can be mounted on any other handfire-arm using corresponding holders.

### 1.3 Scope of supply

Scope of supply, drawing and NATO Stock Nos. change according to the design of the telescope sight.

#### 1.3.1 One telescope sight (Fig. 1)

Drwg. No.: 330148-9001.000  
NATO Stock No.: 1240-12-197-5192  
Designation of stock item: TELESCOPE SIGHT, RIFLE,  
4x magnification

#### 1.3.2 Two protective rubber caps (10)

Drwg. No.: 330148-9002.000  
NATO Stock No.: 5340-12-198-3368  
Designation of stock item: PROTECTIVE CAP, TELESCOPE  
SIGHT, rubber

#### 1.3.3 One grey filter (6)

Drwg. No.: 330108-9003.000  
NATO Stock No.: 1240-12-144-0715  
Designation of stock item: FILTER, LIGHT, TELESCOPE SIGHT

#### 1.3.4 One telescope-sight case with list of contents (20)

Drwg. No.: 330148-9003.000  
NATO Stock No.: 1240-12-302-4921  
Designation of stock item: STORAGE CASE, TELESCOPE  
SIGHT

#### 1.3.5 One tool bag with contents

Drwg. No.: 335917-0000.000  
NATO Stock No.: 1240-12-186-3404  
Designation of stock item: TOOL BAG, with contents  
comprising:

##### 1.3.5.1 One tool bag (23)

Drwg. No.: 335917-8010.000  
NATO Stock No.: 5140-12-146-5698  
Designation of stock item: TOOL BAG

1.3.5.2 One screw driver (22)  
Drwg. No.: 335917-8020.000  
NATO Stock No.: 5120-1 2-121-1092  
Designation of stock item: SCREW DRIVER, LONGITUDINAL SLOT 4.5 x 40 mm blade, 100 mm long

1.3.5.3 One dust brush (21)  
Drwg. No.: TL 7920-0024-22  
NATO Stock No.: 7920-12-120-0355  
Designation of stock item: BRUSH, DUST, OBJECTIVE, squirrel hair, 10 mm dia., goose-quill holder

1.3.5.4 One optics cleaning cloth (24)  
Drwg. No.: TL 6640-003-80 x 115  
NATO Stock No.: 6640-12-124-6982  
Designation of stock item: CLEANING CLOTH, LENS, cotton 80 x 115 mm

1.3.6 Sight holder (19)  
Drwg. No.: H & K 100236 or 100236/8  
NATO Stock No.: 1240-12-140-9932 or  
1249-12-160-0373  
Manufacturing firm: Heckler & Koch, Oberndorf  
Designation of stock item: HOLDER, TELESCOPE SIGHT. RIFLE

1.3.7 One copy of operating instructions (on request)

## 1.4 Technical Data

### 1.4.1 Optical Data

1.4.1.1	Telescope magnification (V)	4x
1.4.1.2	Entrance pupil diameter (EP)	24 mm
1.4.1.3	Exit pupil diameter (AP)	6mm
1.4.1.4	Eye relief	approx. 60 mm
1.4.1.5	Diopter setting	- 0.5 to - 0.75 dpt (fixed)
1.4.1.6	Parallax-free for a distance of	150 mm
1.4.1.7	Field of view angle	6 deg. ^ 106.66
1.4.1.8	Field of view	105 m/1000 m
1.4.1.9	Reticle	sighting thorn with side scale according to FINABLE
1.4.1.10	Attachable filter	grey (NG 4; 2.6 mm thick, approx. 94% absorption)

## 1.4.2 Mechanical Data and Dimensions (Fig. 1)

1.4.2.1	Elevation angle adjustment/ range adjustment	100 to 600 m
	- elevation correction of one click	1 cm/100 m
		approx. 0.1
	- adjustment	1^100 m ^1.74
		2^200 m ^2.29
		3^300 m ^3.24
		4^300 m ^4.43
		5^500 m ^5.87
		6^600 m ^7.57
1.4.2.2	Lateral adjustment	
	- lateral correction of one click	1cm/100 m approx. .1
	- total adjustment	+/- 24 clicks
1.4.2.3	Overtravelling for adjustment	elevation > 2
		lateral > 1

1.4.2.4	All telescope sights have been adjusted to the same point with range setting 1 and lateral setting 0	tolerance +/- 0.5
1.4.2.5	Total length of telescope sight incl. protective rubber caps	226.5 mm
1.4.2.6	Protective rubber cap	39.5 mm dia.
1.4.2.7	Tube	27 mm dia.
1.4.2.8	Eyepiece/Objective	32.5 mm dia.
1.4.2.9	Distance between optical axis and telescope sight support	20.7 mm
1.4.2.10	Telescope sight support	per STANAG 2324
1.4.2.11	Mounting screws	M6: 10.5 mm long
1.4.2.12	Case (external dimensions)	approx. 230 x 105 x 63 mm
1.4.2.13	Distance between optical axis and axis of the bore (incl. sight holder)	87.5 mm

### 1.4.3 Weight

1.4.3.1	Telescope sight	approx. 0.30 kg
1.4.3.2	Telescope sight including sight holder	approx. 0.62 kg
1.4.3.3	Telescope sight including sight holder and accessories in case	approx. 1.00 kg

### 1.5 Construction

#### 1.5.1 General

The telescope sight is a monocular telescope of straight construction with a lens erecting system. For the elevation angle adjustment the sighting thorn is displaced vertically.

#### 1.5.2 Optical Structure (Fig. 2)

The incident light beams penetrate the objective (1) and are imaged into the first focal plane (2), where the reticle with the sighting thorn is located. The reticle pattern can be illuminated via the cylindrical lens (9), if required. By means of the two two-element erecting lenses of the erecting system (4) the image of the first focal plane is imaged into the eyepiece focal plane (7) and viewed through the eyepiece (5). Optionally a grey filter (6) can be mounted before the eyepiece.

### 1.5.3 Mechanical Structure (Fig. 3)

The objective and eyepiece sides of the tube (11) can both be provided with a protective rubber cap (10). Two mounting screws (13) are provided for mounting the sight on the holder.

1.5.3.1 The outer side of the tube accommodates the following components: elevation adjustment (12), lateral adjustment (14), guide bar (25) and telescope sight support (15) per STANAG 2324. Inside the tube the objective (1), the reticle (3), the eyepiece (5), and the erecting system (4) comprising the two two-element erecting lenses are arranged.

1.5.3.2 The protective caps (10) at the objective and eyepiece sides serve for protection against mechanical damage and are closed by inverting when the telescope sight is not in use.

1.5.3.3 The mounting screws (13) serve for screwing the telescope sight to the sight holder. They are provided with self-securing Nylock inserts.

## 2 Operation

### 2.1 Transport (Fig. 6)

For transport and storage the telescope sight together with the sight holder and the accessories is put into the case (20).

### 2.2 Operating Elements

2.2.1 The reticle is designed according to Fig. 4. The reticle pattern consists of the sighting thorn with side scale per FINABEL.

2.2.2 The elevation angle is adjusted by means of the elevation adjustment (12).

2.2.3 Lateral correction is effected by means of the lateral adjustment (14).

2.2.4 The protective rubber caps (10) prevent mechanical damage.

2.2.5 The telescope sight is mounted on the sight holder (19) by means of the mounting screws (13) on the telescope sight support (15).

2.2.6 The grey filter (6) to be inserted into the eyepiece protective cap serves as anti-dazzle device.

- 2.3 Putting Telescope Sight into Operation and Boresighting (Fig. 5)**
- 2.3.1 Mount telescope sight (18) with sight holder (19) on rifle securely.
  - 2.3.2 Open protective rubber caps (10) at eyepiece and objective sides of telescope sight by inverting.
  - 2.3.3 In case of too much glare by sun or snow insert grey filter (6) into eye piece cap.
  - 2.3.4 Set elevation adjustment (12) to 100 m (click 1) and lateral adjustment (14) to 0.
  - 2.3.5 Loosen countersunk screws (16) by means of screw driver (22).
  - 2.3.6 Adjust sight on rifle to 100 m and aim at target 100 m away via notch and bead sights.
  - 2.3.7 Point sighting thorn of telescope sight at same target. For this purpose operate elevation (12) and lateral (14) adjustments using a coin. Make sure that settings as per 2.3.4 remain unchanged.
  - 2.3.8 Fire trial shots and readjust thorn after each shot if required. The turning direction for shot correction is indicated on the disks of the elevation and lateral adjustment (12 and 14).
  - 2.3.9 After adjustment re-tighten countersunk screws (16).

- 2.3.10 Depending on target distance between 100 and 600 m set elevation adjustment (12) to clicks 1 to 6 accordingly. At the same time the sighting thorn is shifted in height and the elevation angle corresponding to the distance is adjusted.

### **3 Maintenance**

- 3.1 Check optics for cleanliness. Clean dirty optics only with dust brush (21) and optics cleaning cloth (24) after breathing on them; do not touch with fingers (dustbrush and optics cleaning cloth are part of accessories). Slight impurities (scratches) on the outer optical surfaces do not impair function of the unit. However, cracked glass components have to be replaced (return unit for repair).
- 3.2 Remove dust and dirt from outer mechanical surfaces with a dry cloth or brush. Remove coarse impurities (such as oil or grease) with a cloth moistened with gasoline. Clean moving parts and fitting surfaces particularly carefully.

- 3.3 Check operating elements for easy motion. Slightly oil moving parts of sight holder using an acid-free oil.
- 3.4 Disinfect protective rubber caps. Moisten clean cloth with a disinfectant solution and wipe rubber parts.
- 3.5 Touch up varnish blemishes using an air-drying varnish per RAIL 90'05 after having degreased the area.

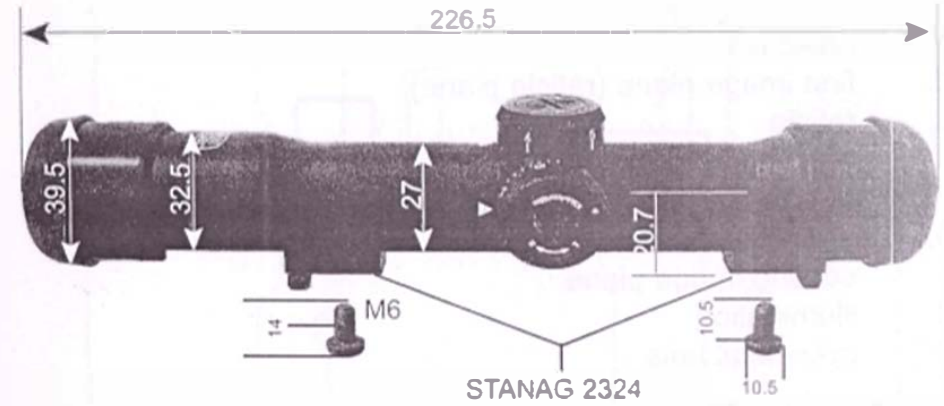

Fig. 1 Main dimensions of the unit

Fig. 2 Optical structure

1. objective
2. first image plane (reticle plane)
3. reticle
4. erecting system
5. eyepiece
6. grey filter
7. second image plane
8. illumination
9. cylindrical lens

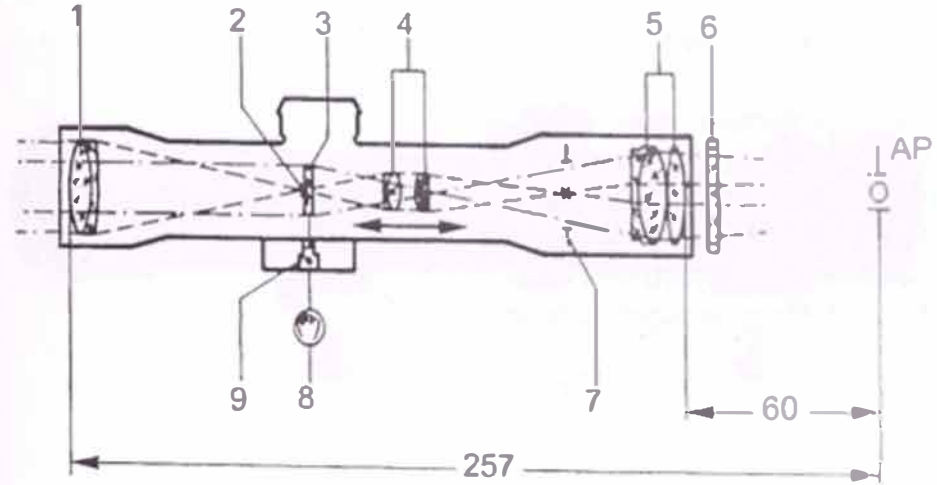

Fig. 3 FER0-Z 24

View from the right

- 10. protective caps
- 11. tube
- 12. elevation adjustment
- 13. M6 mounting screws
- 14. lateral adjustment
- 15. telescope sight support

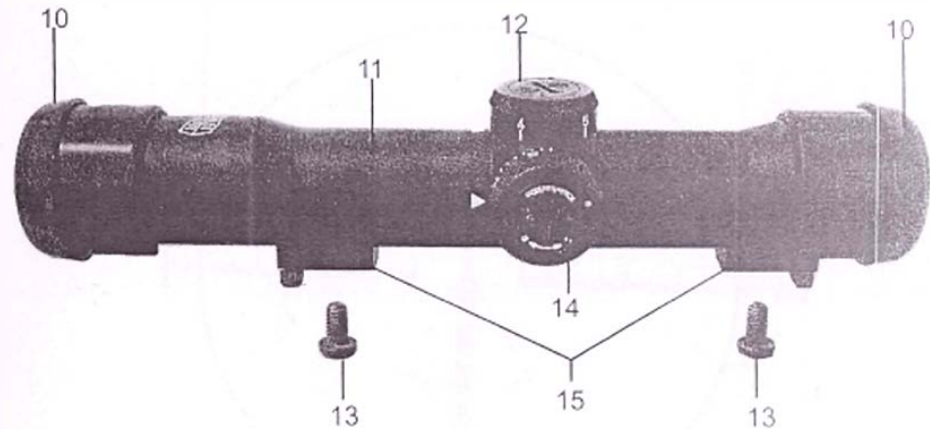

Fig. 4 Reticle pattern

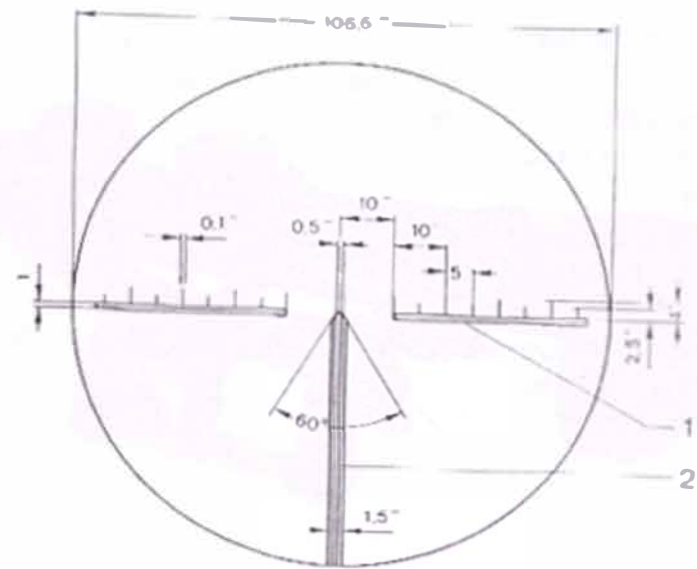

Fig. 5 FERRO-Z 24

View from the left

- 6 grey filter
- 10 protective caps
- 11 tube
- 12 elevation adjustment
- 14 lateral adjustment
- 16 countersunk screws
- 17 elevation adjustment ring
- 18 telescope sight
- 19 sight holder

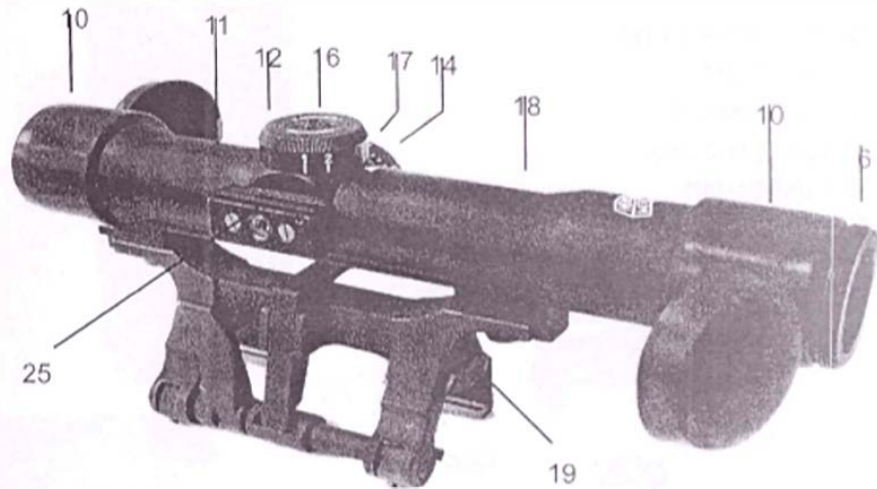

Fig. 6 FER0-Z 24

- 10 protective caps
- 18 grey filter
- 19 sight holder
- 20 storage case
- 21 dust brush
- 22 screw driver
- 23 tool bag
- 24 optics cleaning cloth

