

# **APC223/300/308 PRO HA**

## **OPERATOR MANUAL**



B&T AG  
3608 Thun • Switzerland  
Tel +41 33 334 67 00  
info@bt-ag.ch  
www.bt-ag.ch

## Table of content

1. General rules .....	5
1.1 Safety rules .....	5
1.2 Maintenance rules .....	5
2. Technical specifications.....	6
2.1 Overview - APC223/300/308 PRO .....	6
2.2 General description .....	6
2.3 General technical data.....	7
2.3.1 Technical data - APC223 PRO HA.....	8
2.3.2 Technical data - APC300 PRO HA.....	8
2.3.3 Technical data - APC308 PRO HA.....	9
2.4 Variant overview - APC223/300 PRO.....	10
2.5 Variant overview - APC308 PRO.....	12
3. Nomenclature.....	14
3.1 Weapon complete.....	14
3.2 Weapon disassembled.....	14
4. Handling and operating procedures .....	15
4.1 Clearing weapon .....	15
4.2 Operating fire selector .....	15
4.3 Magazine catch .....	16
4.3.1 Operating magazine catch.....	16
4.4 Stocks.....	17
4.4.1 Closing stock - Stock PRO .....	17
4.4.2 Adjusting length - Stock PRO .....	17
4.4.3 Adjusting cheek rest - Stock PRO.....	18
4.4.4 Opening stock - Stock PRO.....	18
4.4.5 Closing - Folding stock .....	19
4.4.6 Opening - Folding stock .....	19
4.4.7 Retracting - Telescopic stock .....	20
4.4.8 Extracting - Telescopic stock.....	20
4.4.9 Retracting - Brace Adapter.....	21
4.4.10 Extracting - Brace Adapter .....	21
4.4.11 Closing - Helmet stock .....	22
4.4.12 Opening - Helmet stock.....	22
4.4.13 Closing - Foldable M4-Adapter.....	23
4.4.14 Opening - Foldable M4-Adapter .....	23
4.5 Pistol grip storage compartment.....	24
4.5.1 Open the pistol grip cover.....	24
4.5.2 Close the pistol grip cover .....	24
4.6 Iron sights .....	25
4.6.1 Engaging iron sights.....	25
4.6.2 Adjustments.....	25

4.7	Bolt catch.....	26
4.7.1	Locking the bolt in open position .....	26
4.7.2	Closing bolt.....	26
4.8	Gas regulator.....	27
4.8.1	Function.....	27
4.8.4	Positions APC223/308 PRO .....	28
4.8.2	Positions APC300 PRO .....	28
4.8.3	Finding the optimal setting .....	29
4.9	Loading and unloading weapon .....	30
4.9.1	Loading weapon.....	30
4.9.2	Unloading weapon during firing sessions.....	30
4.9.3	Unloading weapon for storage.....	31
4.10	Firing the APC223/300/308 PRO.....	31
5.	Maintenance procedures .....	32
5.1	Scope of cleaning cycles .....	32
5.1.1	Quick cleaning .....	32
5.2	Reassembly.....	33
5.2.1	Reassembly of the weapon.....	33
5.2.2	Disassembly upper receiver.....	37
5.3	Cleaning and inspection .....	38
5.4	Reassembly.....	40
5.4.1	Reassembly of the weapon.....	40
5.4.2	Reassembly of upper receiver .....	45
5.5	Functional check .....	46
5.6	Troubleshooting table .....	47
6.	Accessories.....	48
6.1	Suppressors .....	48
6.2	Stocks / Adapters.....	49
6.3	Magazines.....	51
6.4	Flashlights.....	52
6.5	Brass catcher .....	52
6.6	Grips .....	53
6.7	Sights .....	54
6.8	Maintenance .....	55
7.	Warranty statement .....	56

**Related documents:**

Parts catalogue .....	PC-APC223 PRO-HA-EN
Parts catalogue .....	PC-APC556 PRO-HA-EN
Parts catalogue .....	PC-APC300 PRO-HA-EN
Parts catalogue .....	PC-APC308 PRO-HA-EN

<b>ADVICE!</b>	
	<p>This operator manual covers the entire APC223/556/300/308 weapon family. On the Pictures show normally the Standard Version. Where necessary the operating steps are shown separately for the different variants</p> <p>Due to continuous efforts to improve the weapon, it is possible that certain descriptions in this manual may differ from the actual weapon.</p>

**Abbreviations**

POA:	Point of Aim
POI:	Point of Impact
MPI:	Mean Point of Impact
Left / right side:	Defined looking in firing direction.

<b>EYE PROTECTION MUST BE WORN!</b>	
	<p>SAFETY GOGGLES MUST BE WORN WHEN DISASSEMBLING AND REASSEMBLING THE GUN. PARTS CAN GET INTO THE EYES IF HANDLED INCORRECTLY.</p>

<b>EAR PROTECTION MUST BE WORN!</b>	
	<p>SUITABLE HEARING PROTECTION MUST ALWAYS BE WORN WHEN SHOOTING WITH A FIREARM.</p>

# 1. General rules

Read manual before use.

## 1.1 Safety rules

1. Consider every weapon loaded until checked personally by the individual operator.
2. Always keep fingers off the trigger and outside the trigger guard until the sights are on target.
3. Always point the weapon in a safe direction.
4. Verify your target and the backstop.
5. Before firing always verify the serviceability and condition of both the weapon and ammunition.
6. Hearing and eye protection are mandatory.
7. Be sure to use NATO, SAAMI or CIP certified cartridges of correct caliber only.

### SAFETY ADVICE!



Defects that can be traced back to the use of non NATO, SAAMI or CIP ammunition (especially reloaded cartridges) are not covered by the guarantee!

8. If a cartridge fails to ignite, keep the muzzle pointed in a safe direction and open the chamber only after a minimum of 30 seconds.
9. Live fire training should be carried out in open or well-ventilated areas to prevent excessive exposure to toxic gases.
10. Operate your weapon consciously and do not use excessive force.

## 1.2 Maintenance rules

1. The weapon is to be cleaned according to the following cleaning interval or after each deployment/shooting training.
  - » If the weapon is used **with** a silencer, a quick cleaning should be carried out every 350 shots and a major cleaning every 1000 shots (see chapter “5.1.1 Quick cleaning” on page 32).
  - » When using the weapon **without** silencer, a quick cleaning should be carried out every 500 rounds and a major cleaning every 1000 rounds (see chapter “5.1.2 Major cleaning” on page 32).
2. Any malfunctions are to be reported to the unit armorer or manufacturer.
3. The weapon is to be presented to the unit armorer for inspection after each mission or a minimum of once per year.

## 2. Technical specifications

### 2.1 Overview - APC223/300/308 PRO



### 2.2 General description

The APC223/300/308 PRO is a self-loading rifle in .223 Rem. / .300 Blk. / .308 Win. caliber.

The rifle is a gas operated rifle with a short-stroke gas piston system: the gas port near the muzzle directs the propellant gases behind the projectile via gas piston onto the bolt carrier and sets it in a recoiling motion. After the projectile has left the barrel, the recoiling bolt carrier unlocks the bolt head by means of a rotary movement. In the common recoil of the bolt head and carrier, the empty case is extracted and ejected, the hammer is cocked and the recoil spring compressed. At the end of the return stroke, a recoil buffer slows down the movement of the carrier and then the recoil spring accelerates it forward again. In the common forward stroke, the bolt head and carrier take a new cartridge from the magazine and feed it into the chamber. At the end of such a cycle, the gun is locked, loaded and cocked.

All operating elements such as the bolt catch, magazine catch, fire selector and charging handle are designed to be operated from both sides. The charging handle is not reciprocating.

## 2.3 General technical data

<b>Designation</b>	<b>APC_PRO HA</b>
Manufacturer	B&T AG - Schweiz
Operating system	Short stroke gas piston
Sights	Iron sights (on NAR)
Bore height	80 mm
Rail height	45.7 mm
Interfaces	4 NATO accessory rail
Scope of delivery	Weapon with magazines, carrying sling, cleaning kit, case

Stock Options	Stock length			Stock width		Weight difference to Standard	
	retracted	extracted	folded / retracted	folded out / retracted	folded / retracted	.223/300	.308
	[mm]					[g]	
Fold- retract. stock PRO*	193	270	30	52	84	0 (491)	0 (543)
Folding stock	240	n.v.	30	621	102	-72	-66
Fixed stock	193	n.v.	n.v.	102	n.v.	-10	-5
Helmet stock	232	293	30	62	105	-125	-119
Telescopic stock	n.v.	232	53	55	n.v.	+55	-17
Teleskop. Brace Adapter	n.v.	216	67	55	n.v.	+30	+23
Pistol adapt	30	n.v.	n.v.	62	n.v.	-301	-295
M4-Adapter foldable **	59	n.v.	30	62	102	-251	-245
NAR-Adapter	20	n.v.	n.v.	38	n.v.	-315	-368

\* Standard - Maximal extracted, intermediate positions present

\*\* without M4 stock

Technical data are provided for information only and shall not serve as acceptance criteria.

### 2.3.1 Technical data - APC223 PRO HA

<b>Designation</b>	<b>APC223 PRO HA</b>
Product ID	BT-361603
Caliber	.223 Remington
Magazine capacity	30 rounds
Rifling	6 Grooves, right hand twist

Type		Standard Barrel 264 mm	Barrel 222 mm	Barrel 308 mm	Barrel 420 mm
Barrel length	[mm]	264	222	308	420
Length standard	[mm]	723	680	766	878
Length receiver	[mm]	530	487	573	685
Width	[mm]	53	53	53	53
Height*	[mm]	211	211	211	211
Weight	[kg]	3.27	3.23	3.39	3.69

\* Without magazine, flip-up sights folded..

### 2.3.2 Technical data - APC300 PRO HA

<b>Designation</b>	<b>APC300 PRO HA</b>
Product ID	BT-361563
Caliber	.300 Blackout
Magazine capacity	30 rounds
Rifling	4 Grooves, right hand twist

Barrel length	[mm]	222
Length standard	[mm]	682
Length receiver	[mm]	489
Width	[mm]	53
Height*	[mm]	211
Weight	[kg]	3.15

\* Without magazine, flip-up sights folded.

### 2.3.3 Technical data - APC308 PRO HA

<b>Designation</b>	<b>APC308 PRO HA</b>
Product ID	BT-361693
Caliber	.308 Winchester
Magazine capacity	20 rounds
Rifling	4 Grooves, right hand twist

<b>Type</b>		<b>Standard Barrel 330 mm</b>	<b>Barrel 363 mm</b>	<b>Barrel 480 mm</b>
Barrel length	[mm]	330	363	480
Length standard	[mm]	823	698	983
Length receiver	[mm]	630	667	790
Width	[mm]	53	53	53
Height*	[mm]	211	211	211
Weight	[kg]	4	4.1	4.5

\* Without magazine, flip-up sights folded.

## 2.4 Variant overview - APC223/300 PRO

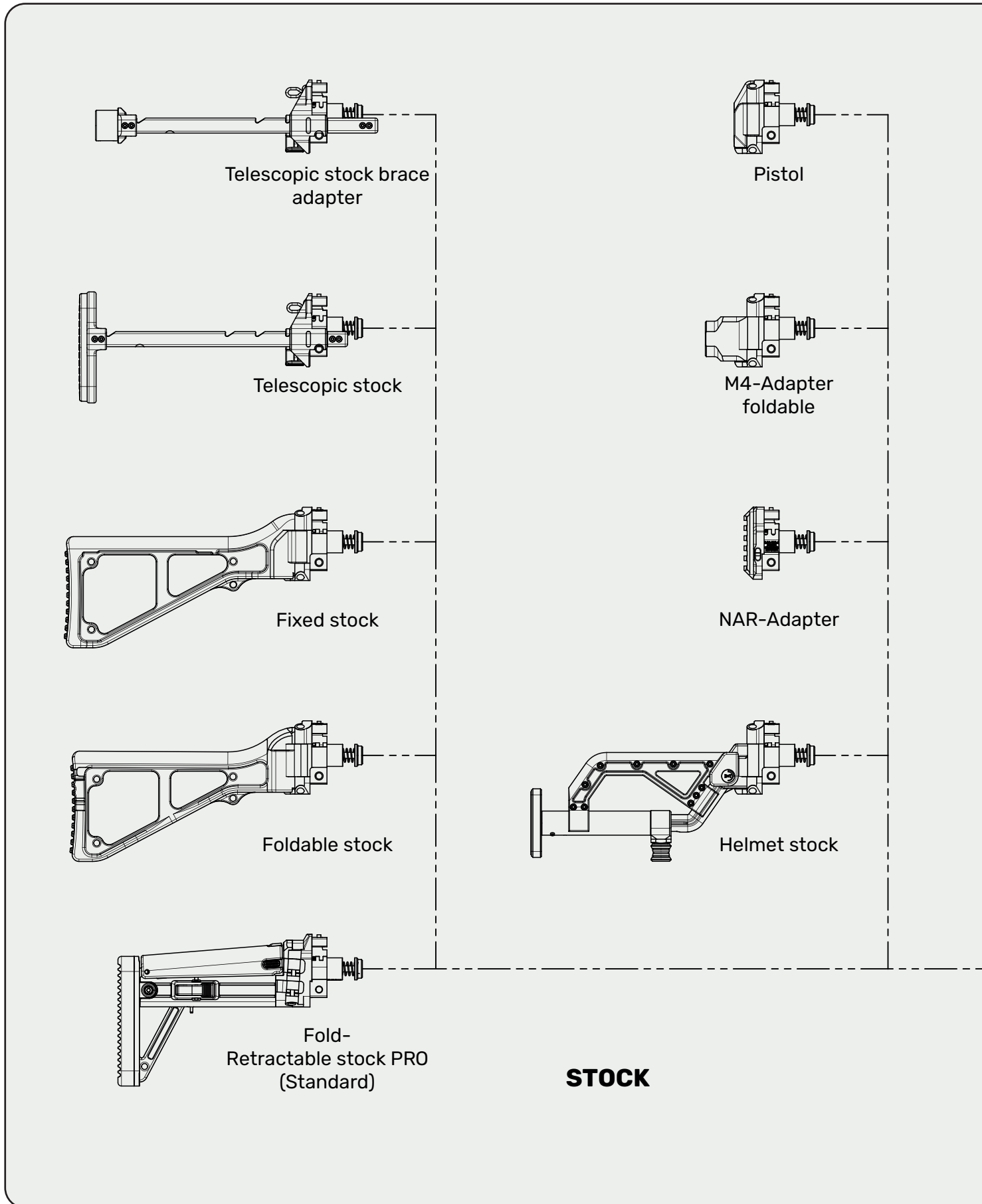

Barrel length 420 mm

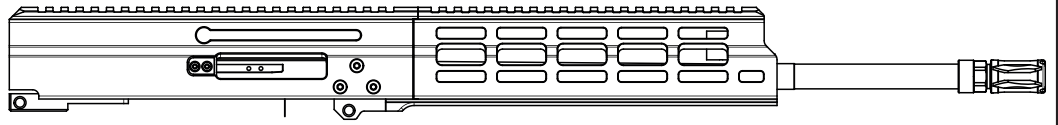

Barrel length 308 mm

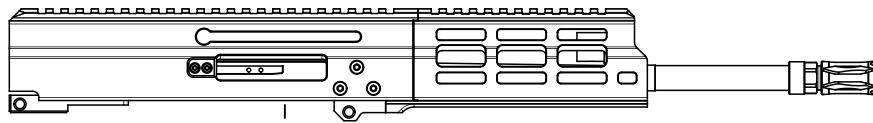

Barrel length 264 mm (standard)

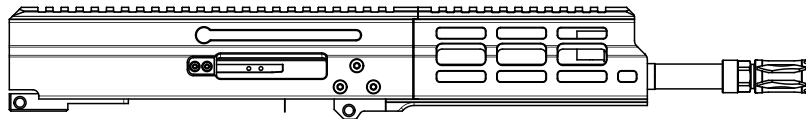

Barrel length 222 mm

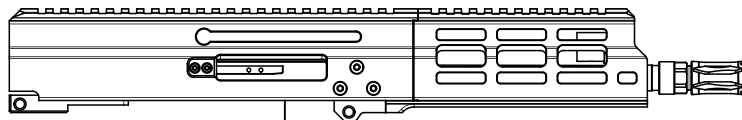

**UPPER RECEIVER**

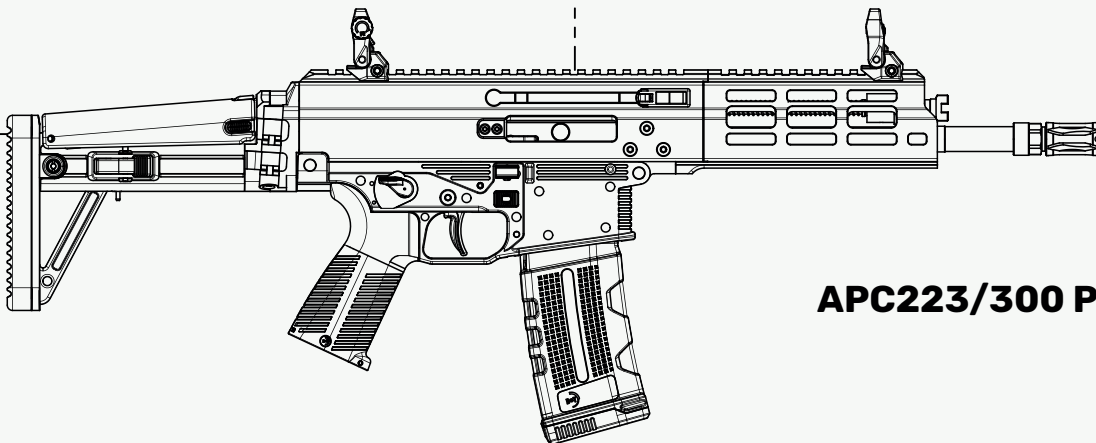

**APC223/300 PRO**

## 2.5 Variant overview - APC308 PRO

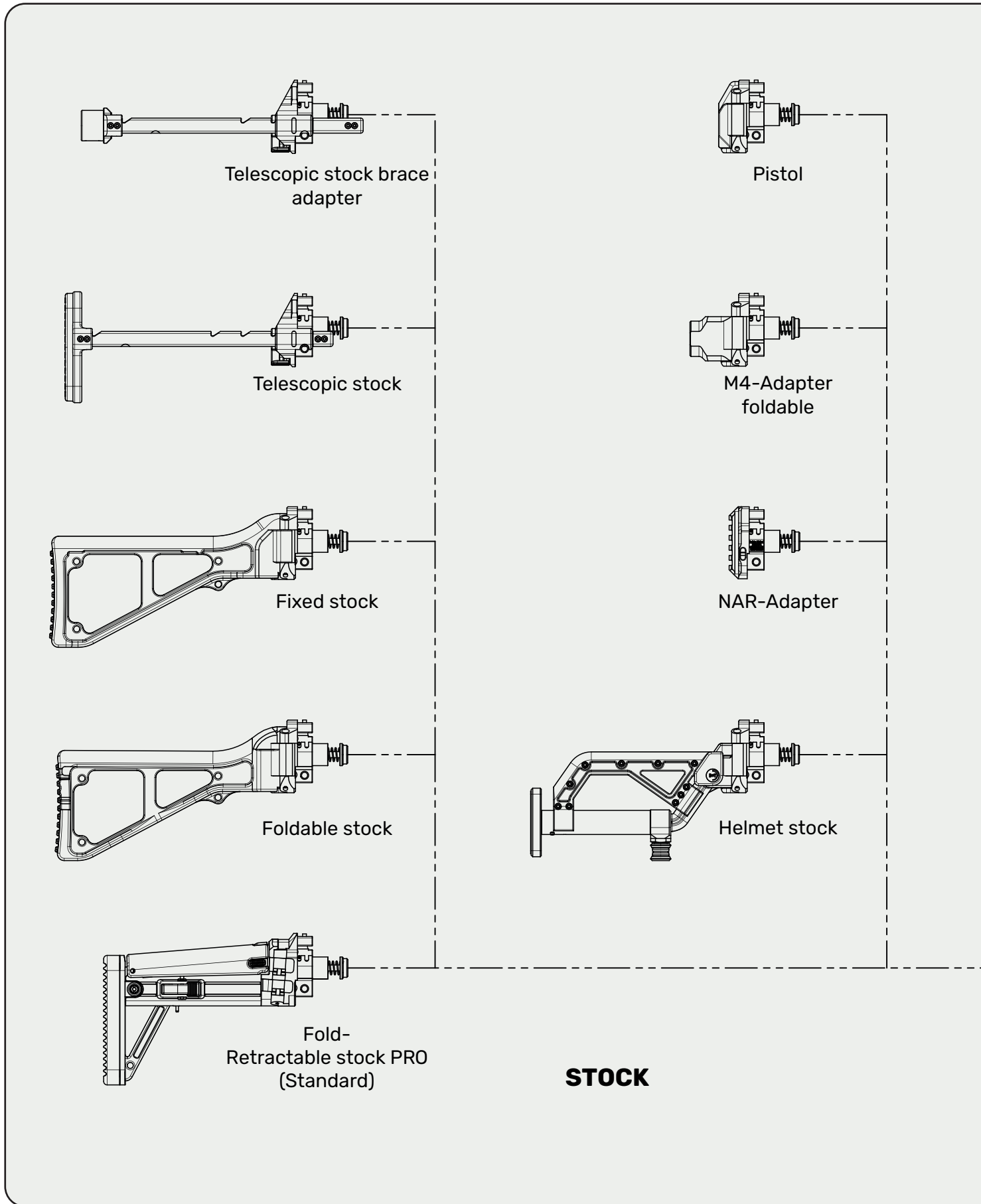

Barrel length 480 mm

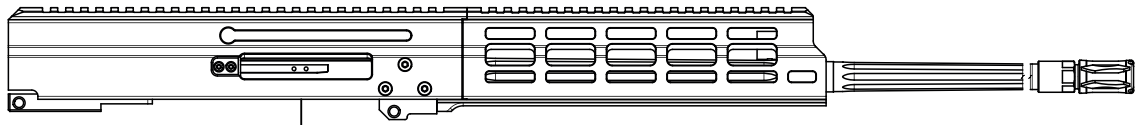

Barrel length 363 mm

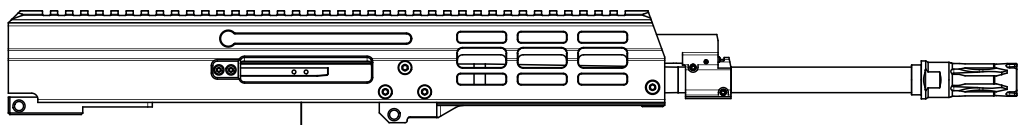

Barrel length 330 mm (standard)

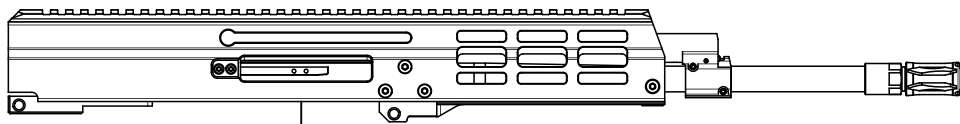

**UPPER RECEIVER**

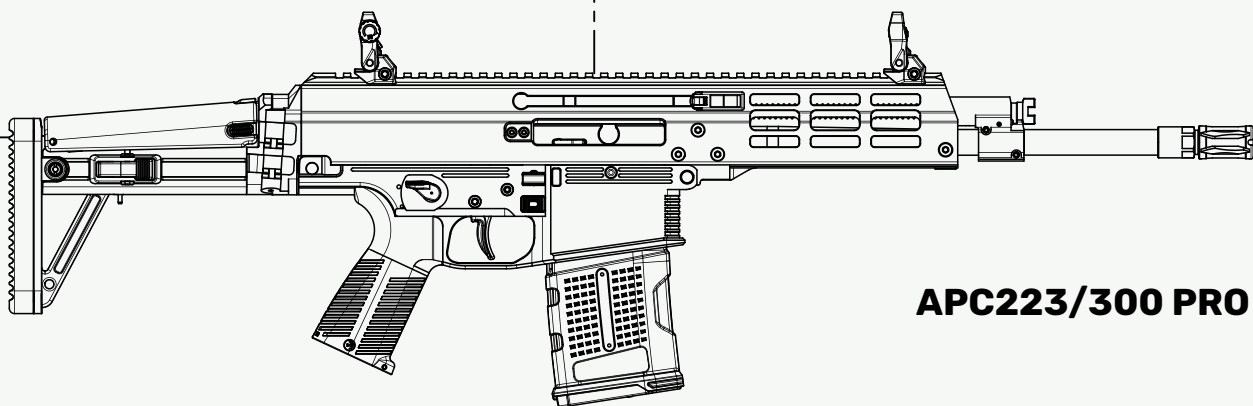

**APC223/300 PRO**

### 3. Nomenclature

#### 3.1 Weapon complete

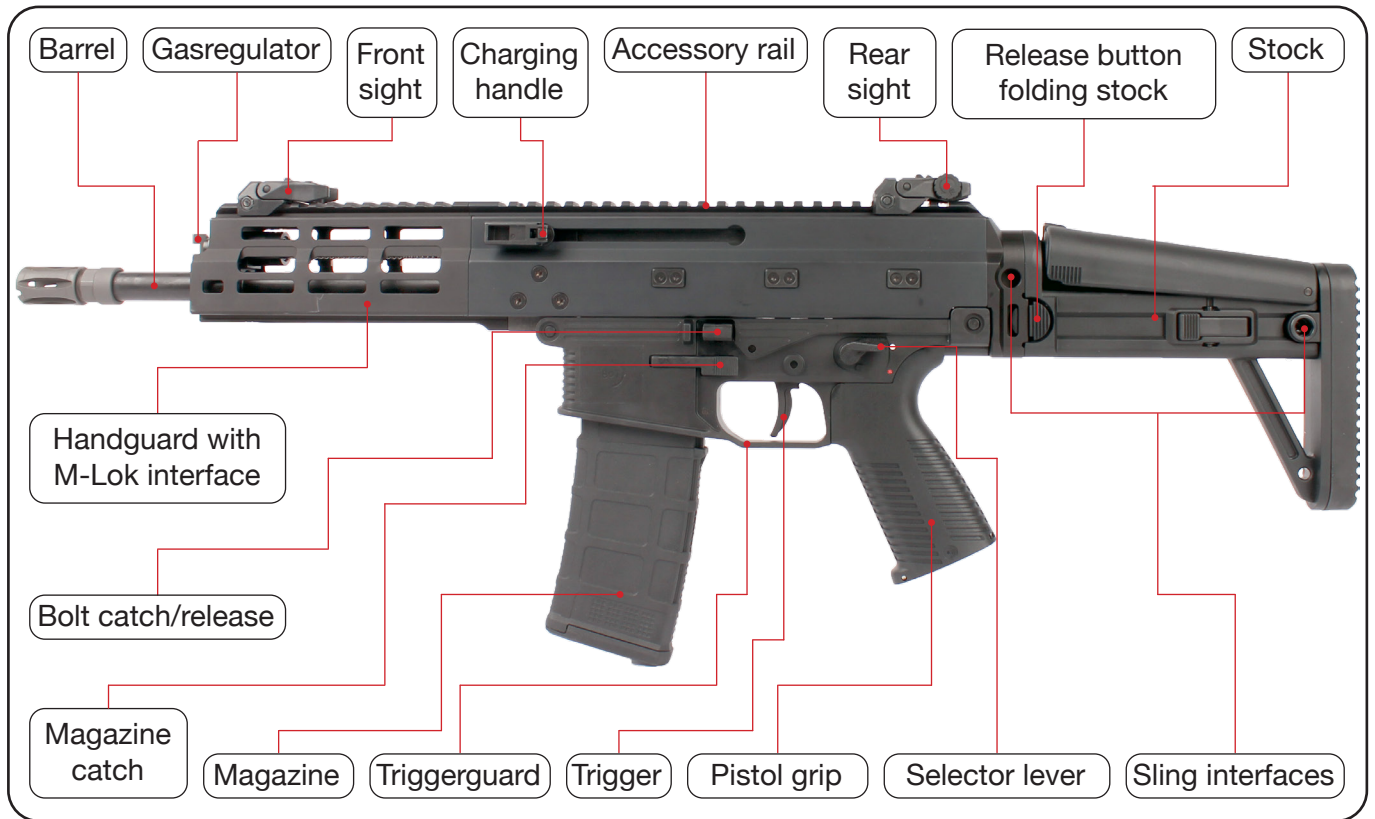

#### 3.2 Weapon disassembled

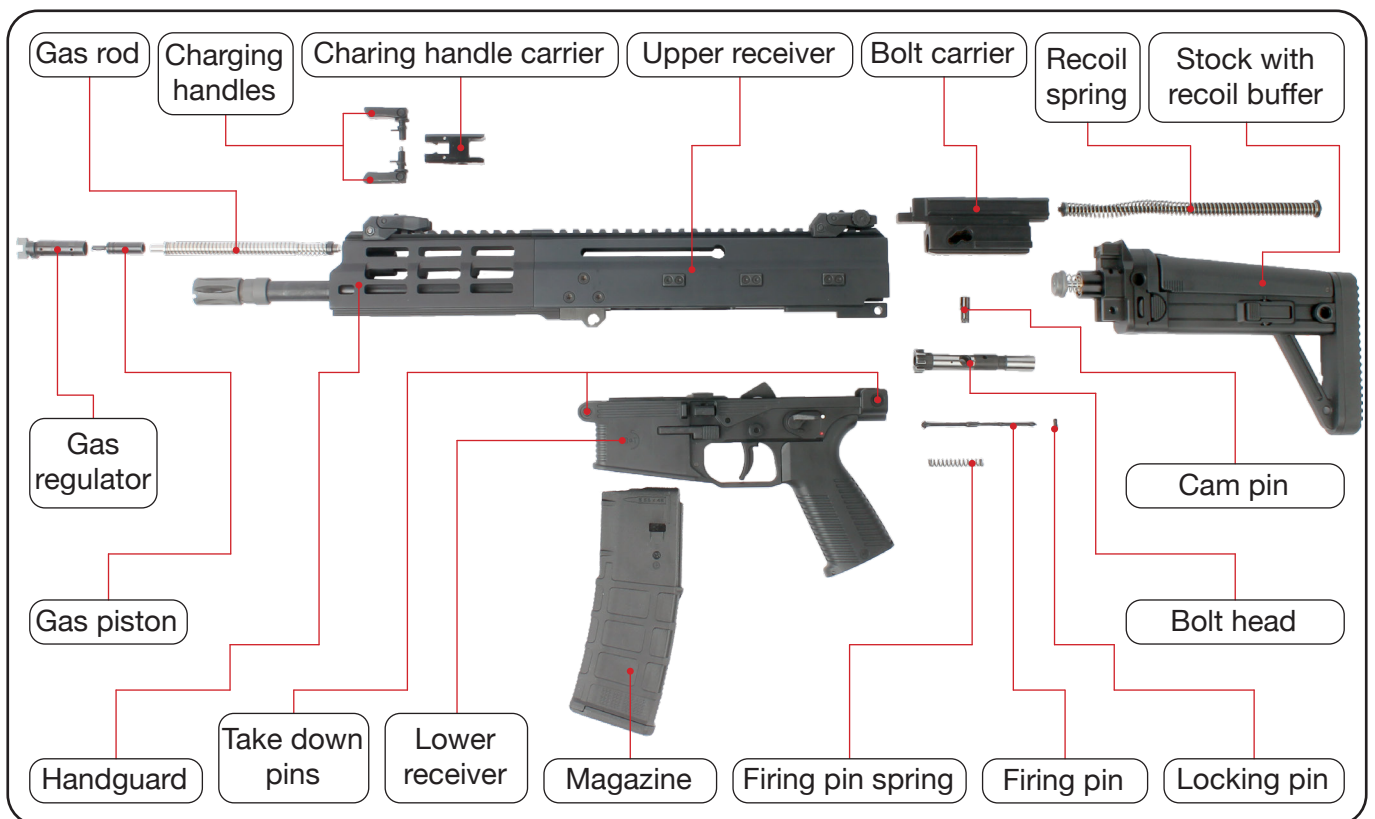

## 4. Handling and operating procedures

### 4.1 Clearing weapon

- Rotate the fire selector to «safe» position (chapter 4.2 on page 15).
- Press the magazine retainer and pull the magazine downward out.

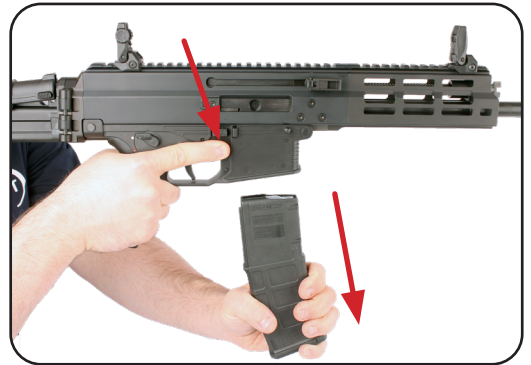

- Pull the charging handle completely to the rear and inspect the chamber visually to be clear.
- Lock the bolt in open position (chapter 4.7.1 on page 26).



### 4.2 Operating fire selector

- The positions of the fire selector are marked on both side of the weapon.
- Rotate the fire selector in order to engage the desired mode.



WHITE DOT = SAFE

RED DOT= SINGLE FIRE

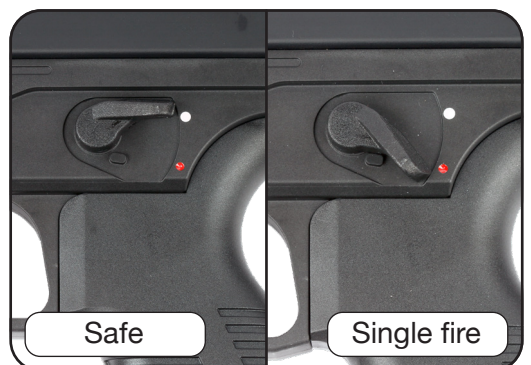

### 4.3 Magazine catch

The Magazine catch is present on both side of the weapon.

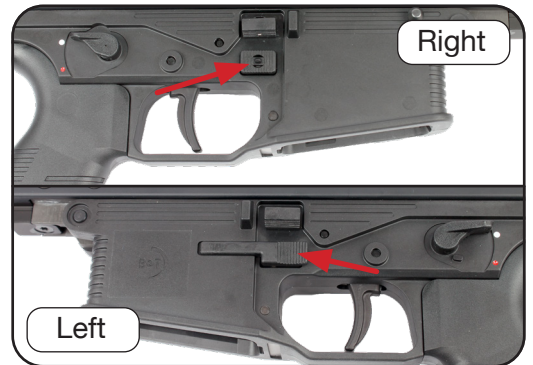

#### 4.3.1 Operating magazine catch

- Rotate the fire selector to «safe» position (chapter 4.2 on page 15).
- Press the magazine retainer and pull the magazine downward out.



## 4.4 Stocks

### 4.4.1 Closing stock - Stock PRO

- Grasp the weapon with the firing hand on the pistol grip.
- Push the locking knob with the non firing hand, and fold it.



- Fold the stock until it reaches the end position and slides in the locked position.



### 4.4.2 Adjusting length - Stock PRO

- Press and hold both locking knobs with one hand.

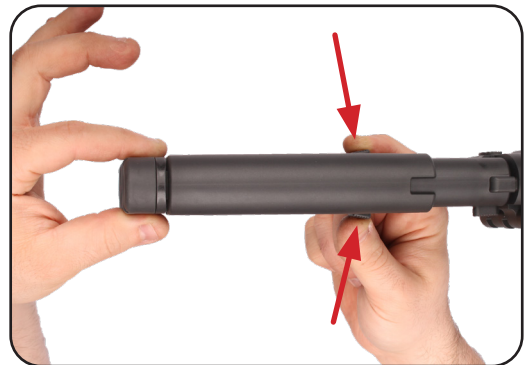

- With the other hand pull out or push in the shoulder support to the desired length.
- At the position, release the locking knobs and ensure that the shoulder support is locked in place by pulling gently on it.

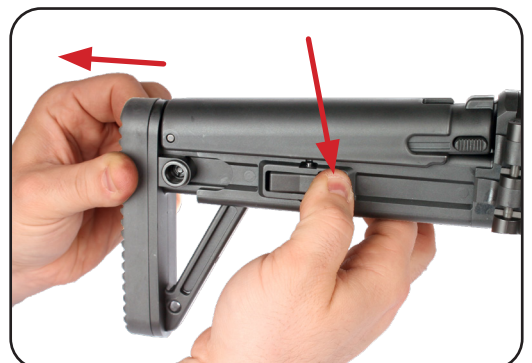

#### 4.4.3 Adjusting cheek rest - Stock PRO

- a. Hold the weapon with the firing hand on the pistol grip.
- b. Press and hold the adjustment knob on the cheek rest with the other hand.

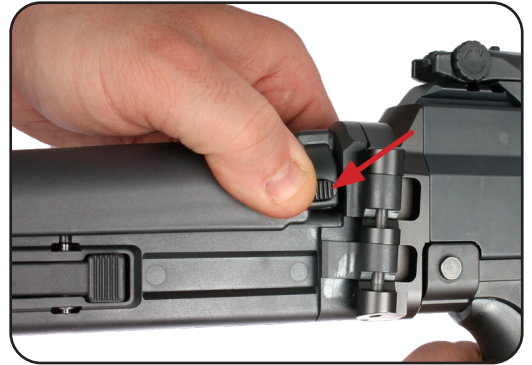

- c. Adjust the cheek rest until it audibly engages in the desired position.



#### 4.4.4 Opening stock - Stock PRO

- a. Hold the weapon with the firing hand on the pistol grip.
- b. With the other hand, grasp the folding stock at the interface, lift it upwards out of the lock and unfold it until it audibly engages.



- c. Use the non-firing hand to check the correct locking of the stock.



#### 4.4.5 Closing - Folding stock

- a. Grasp the weapon with the firing hand on the pistol grip.
- b. Push the Locking knob with the non firing hand, and fold the stock



- c. Fold in the stock until it reaches the end position and locks audibly.



#### 4.4.6 Opening - Folding stock

- a. Grasp the weapon with the firing hand on the pistol grip.
- b. Grasp the folding stock with the non firing hand, and fold it out.



- c. Fold out the stock until it reaches the end position and locks audibly.
- d. Use the non-firing hand to check the correct locking of the stock

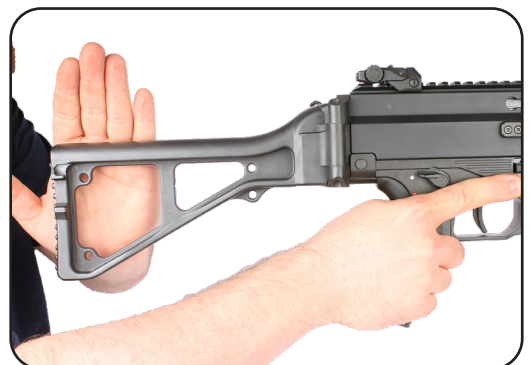

#### 4.4.7 Retracting - Telescopic stock

- a. Grasp the weapon with the firing hand on the pistol grip.
- b. Push the locking knob with the thumb of the firing hand, and push in the stock.

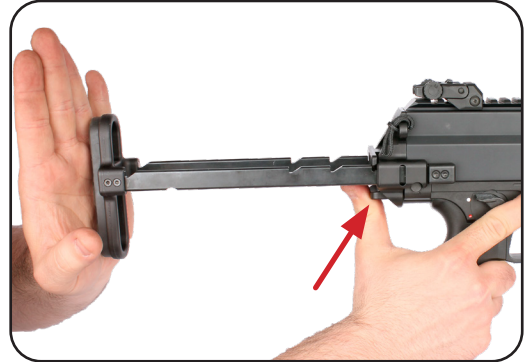

- c. Push in the stock until it reaches the end position and locks audibly.

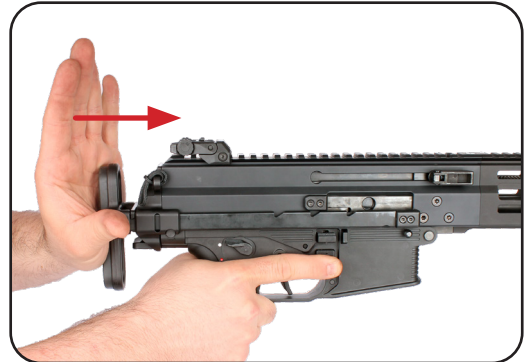

#### 4.4.8 Extracting - Telescopic stock

- a. Grasp the weapon with the firing hand on the pistol grip.
- b. Pull out the stock with the non firing hand.

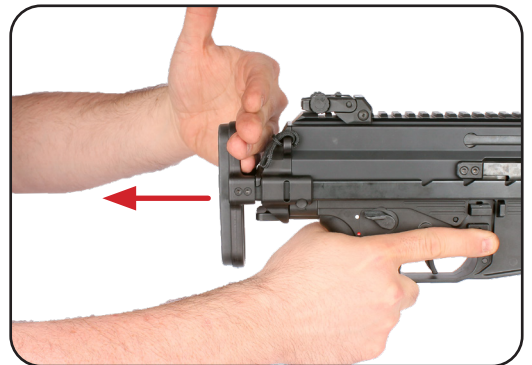

- c. Pull out the stock until it reaches the desired position.
- d. Then release the locking knob and lock the stock on one of the various locking positions.

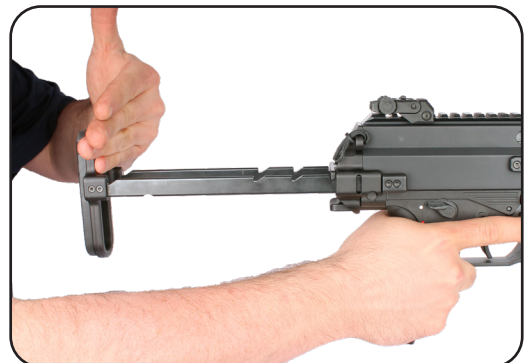

#### 4.4.9 Retracting - Brace Adapter

Advice!	
	For the operation of the Brace, refer to the Brace operating instructions.

- Grasp the weapon with the firing hand on the pistol grip.
- Push the locking knob with the thumb of the firing hand, and push in the stock.
- Push in the stock until it reaches the end position and locks audibly.

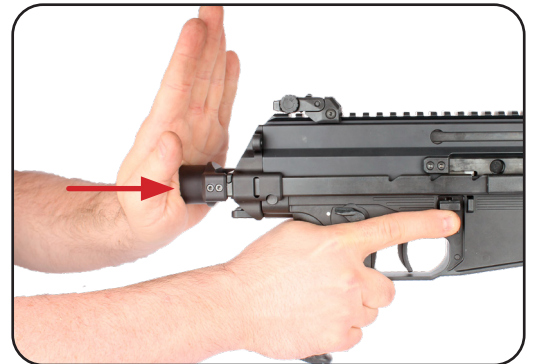
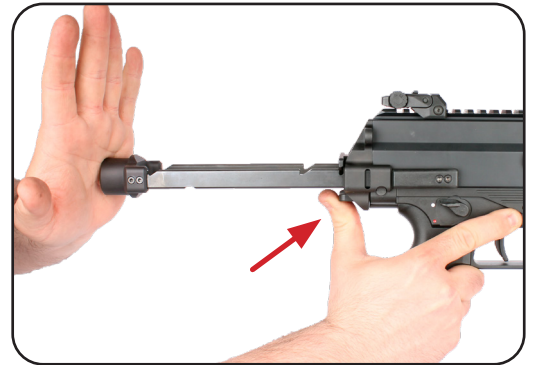

#### 4.4.10 Extracting - Brace Adapter

- Grasp the weapon with the firing hand on the pistol grip.
- Pull out the stock with the non firing hand.
- Pull out the stock until it reaches the desired position.
- Then release the locking knob and lock the stock on one of the various locking positions.

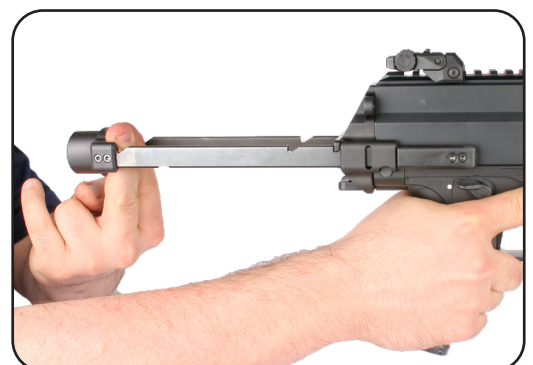
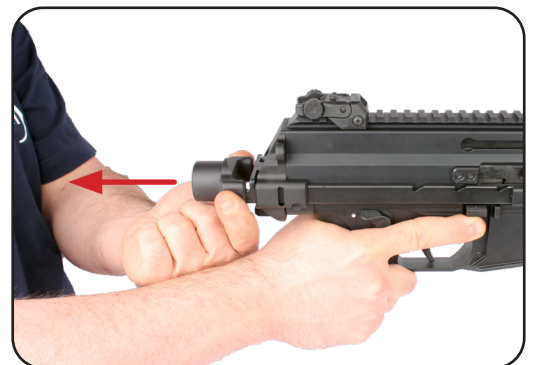

#### 4.4.11 Closing - Helmet stock

- a. Grasp the weapon with the firing hand on the pistol grip.
- b. Pull the adjustment knob with your non firing hand and retract the stock as far as it will go.
- c. Push the Locking knob with the non firing hand, and fold it in.
- d. Fold in the stock until it reaches the end position.

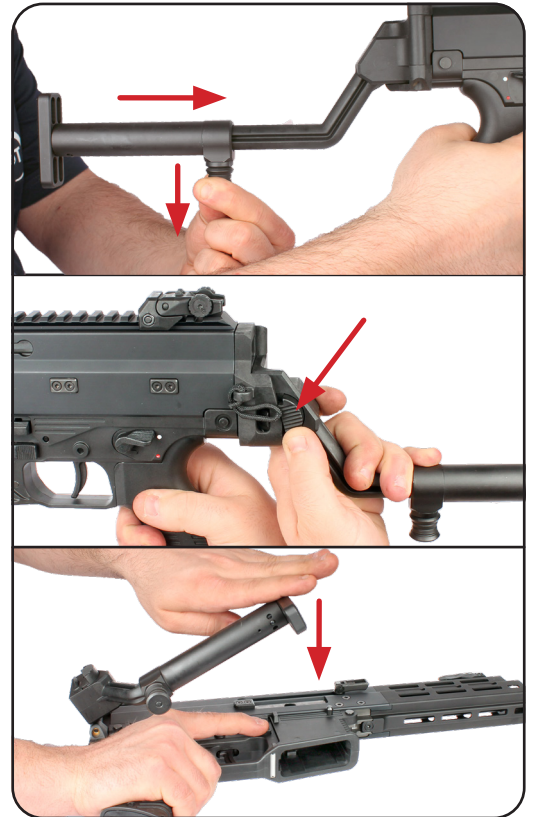

#### 4.4.12 Opening - Helmet stock

- a. Grasp the weapon with the firing hand on the pistol grip.
- b. Grasp the the end of the stock with the non firing hand, and fold it out the stock.
- c. Fold out the stock until it reaches the end position and locks audibly.
- d. Use the non-firing hand to check the correct locking of the stock.
- e. Pull the adjustment knob with the non firing Hand an pull out the stock until it reaches the desired position.

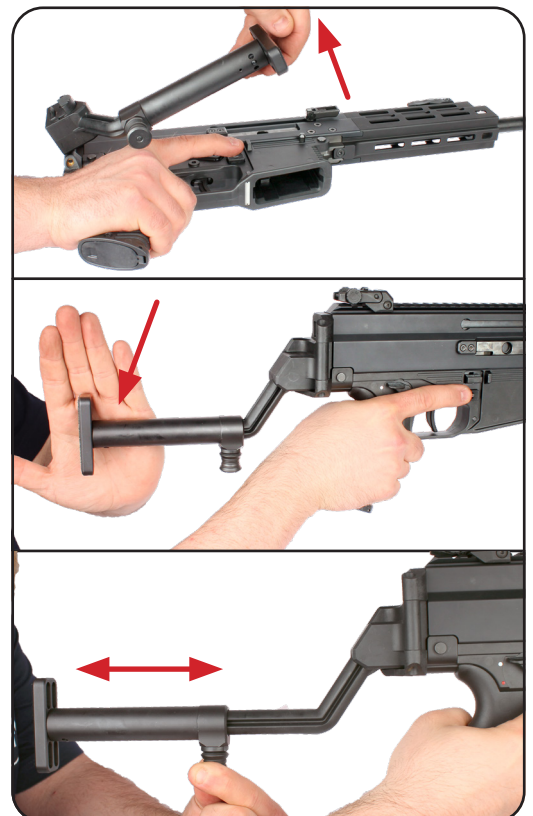

#### 4.4.13 Closing - Foldable M4-Adapter

Advice!	
	For the operation of the used stock, refer to the stock operating instructions.

- a. Grasp the weapon with the firing Hand on the pistol grip, push the Locking knob with the other hand, and fold it.



- b. Fold the M4 Adapter until it reaches the end position.



#### 4.4.14 Opening - Foldable M4-Adapter

- a. Grasp the weapon with the firing Hand on the pistol grip.
- b. Grasp the the end of the M4-Adapter with the non firing hand, and fold it out the stock.



- c. Fold out the M4-Adapter until it reaches the end position and locks audibly.
- d. Use the non-firing hand to check the correct locking of the M4-Adapter.



## 4.5 Pistol grip storage compartment

### 4.5.1 Open the pistol grip cover

- a. Slide a screw driver in the gap at the front of the compartment cover.
- b. Push the cover backward and lift it up.



### 4.5.2 Close the pistol grip cover

- a. In order to close the cover, push it back until it audibly snaps into closed position.



## 4.6 Iron sights

### 4.6.1 Engaging iron sights

- a. Push front sight up until it snaps in upright position.
- b. Push rear sight up until it snaps in upright position.

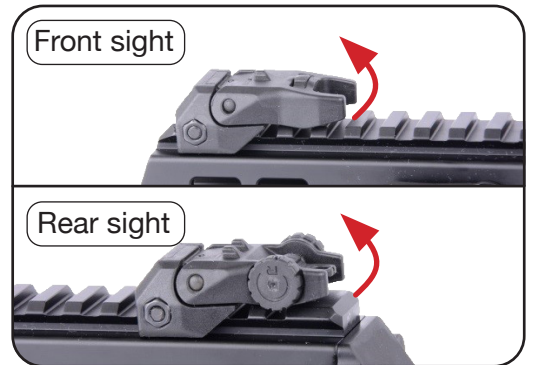

- c. Select large or small aperture.

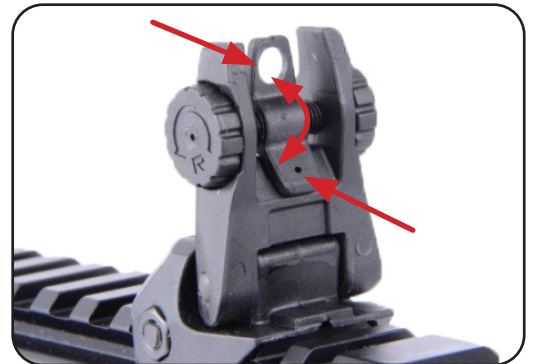

### 4.6.2 Adjustments

- a. Turn the adjusting wheel in the front sight in the direction of the arrow «UP» to raise the MPI.



- b. Turn the rear sight wheel in the direction of the arrow «R» to move the MPI to the right.



## 4.7 Bolt catch

### 4.7.1 Locking the bolt in open position

- a. Remove magazine (chapter 4.3 on page 16).
- b. Grab the charging handle and pull the bolt to the rear-most position and hold it there.



- c. Push the bolt catch upwards (available on left and right weapon side).
- d. Allow the bolt to travel forward until stopped and held by the bolt catch.
- e. Push the charging handle to its foremost position.



### 4.7.2 Closing bolt

- a. Push the external bolt catch (available on left and right weapons side) until the bolt snaps into closed position



## 4.8 Gas regulator

### 4.8.1 Function

In the standard versions of the APC223/300/308 PRO there are usually 3 different gas nozzle positions.

The different positions differ in the size of the diameter of the gas nozzle, which controls the necessary amount of gas for the function of the gun.

By changing the gas regulator, the diameter is changed and thus the gas quantity is increased or decreased.

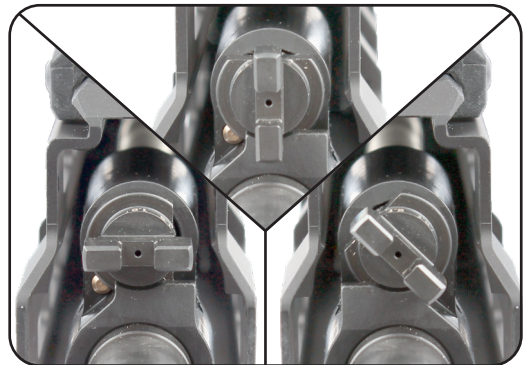

The gas regulator can be changed by turning it clockwise or counterclockwise.

- a. Turn the gas regulator until it audibly engages in the desired position.

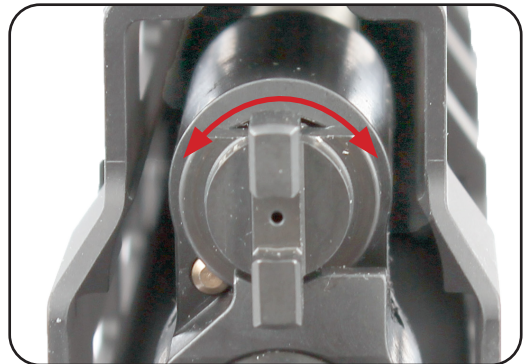

#### Advice!



If the weapon is heated up, change the Position using an appropriate tool.



#### SAFETY ADVICE!



«CHAPTER „4.8.3 FINDING THE OPTIMAL SETTING“ ON PAGE 29» MUST BE OBSERVED!  
IF THE GAS NOZZLE IS INCORRECTLY ADJUSTED, THE RECOIL IS AMPLIFIED, WHICH PLACES AN UNNECESSARY LOAD ON THE GUN AND CAN LEAD TO MALFUNCTIONS.



#### 4.8.2 Positions APC300 PRO

The different diameters are clearly engraved, the number which is visible from above in the vertical position is decisive.

##### GAS REGULATOR - SMALLEST DIAMETER

For shooting with suppressor and supersonic ammunition, set the gas regulator to the smallest possible diameter.

##### GAS REGULATOR - INTERMEDIATE DIAMETER

For shooting without suppressor and supersonic ammunition, set the gas regulator to the intermediate diameter.

##### GAS REGULATOR - LARGEST DIAMETER

For shooting with suppressor and subsonic ammunition, set the gas regulator to the largest possible diameter.

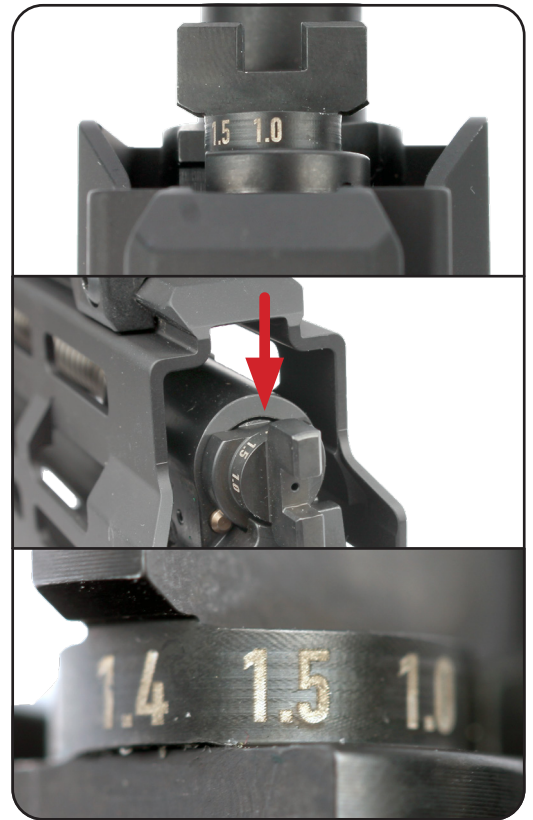

#### 4.8.4 Positions APC223/308 PRO

The different diameters are clearly engraved, the number which is visible from above in the vertical position is decisive.

##### GAS REGULATOR - SMALLEST DIAMETER

For shooting with suppressor, set the gas regulator to the smallest possible diameter.

##### GAS REGULATOR - INTERMEDIATE DIAMETER

For shooting without suppressor, set the gas regulator to the intermediate diameter.

##### GAS REGULATOR - LARGEST DIAMETER

If feed or ejection problems occur due to heavy fouling, set the gas regulator in the largest diameter. If the gun can only be operated in this position, cleaning is urgently recommended. (chapter 5.2 on page 33).

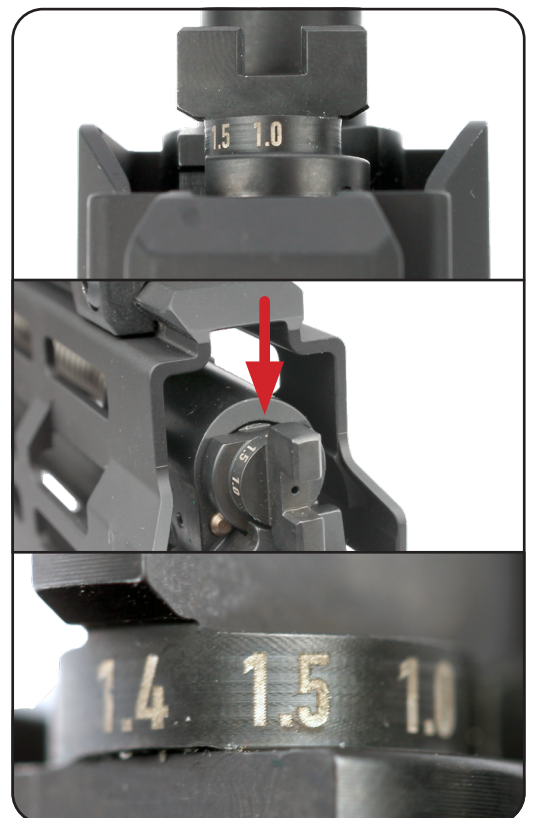

### 4.8.3 Finding the optimal setting

- a. Set the gas regulator in the smallest diameter.
- b. Prepare five rounds and load one into the magazine.
- c. Fire one shot and make sure the bolt is held in the open position. (Last round bolt hold open)
- d. If the bolt is held in the open position, repeat the procedure with the remaining four rounds.
- e. If malfunctions or failures occur, repeat the procedure with the next larger gas nozzle bore until proper function is ensured.

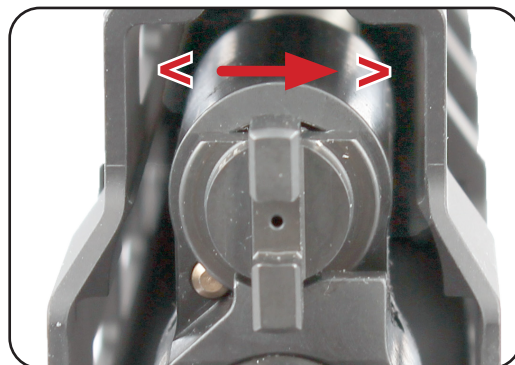

## 4.9 Loading and unloading weapon

### 4.9.1 Loading weapon

- Fill the cartridges one by one into the magazine.
- Grab the weapon and engage safety (chapter 4.2 on page 15).
- Insert magazine.
- Pull the magazine slightly downward to verify it is locked in place.



- If the bolt is open, push the external bolt catch downwards.
- If the bolt is closed, vigorously pull back the charging handle to its rearmost position and allow the bolt to snap forward under its own power.



- Slightly pull the bolt rearward until you can spot the brass of the chambered cartridge in order to verify the weapon is loaded.



### 4.9.2 Unloading weapon during firing sessions

- Engage safety (chapter 4.2 on page 15).
- Remove the magazine (chapter 4.3 on page 16).
- Pull the charging handle rearward and observe the chambered cartridge being ejected.
- Hold the bolt in open position using the bolt catch (chapter 4.7.1 on page 26) and make a visual check to see if the chamber is empty.
- Recover the loose cartridge.

### 4.9.3 Unloading weapon for storage

- a. Unload the weapon (chapter 4.9.2 on page 30).
- b. Close the bolt (chapter 4.7.2 on page 26).
- c. Disengage safety (chapter 4.2 on page 15).
- d. Point the weapon into a safe direction and pull the trigger - the hammer strikes audibly.
- e. Engage safety (chapter 4.2 on page 15).
- f. Lock the Bolt to the rear (chapter 4.7.1 on page 26).
- g. Insert the "Safety-Flag".
- h. Escort the bolt, with inserted safety flag, to the front.

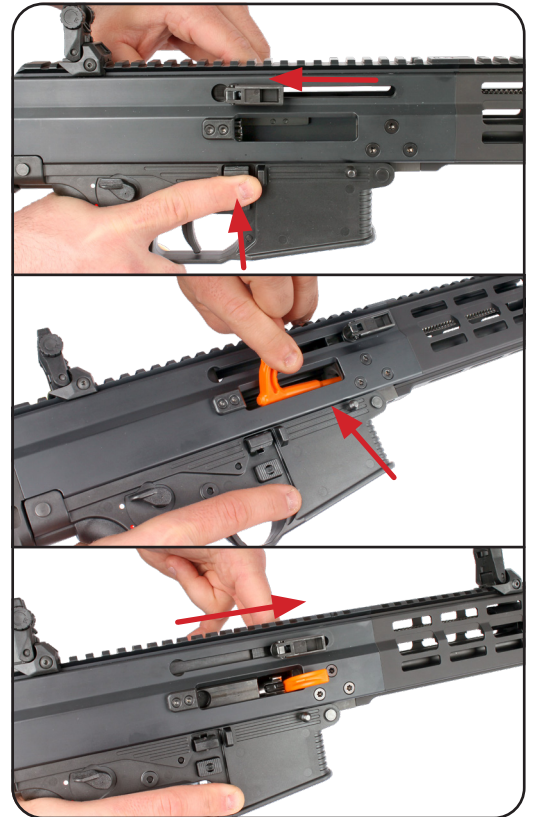

### 4.10 Firing the APC223/300/308 PRO

SAFETY ADVICE!	
	REFER TO CHAPTER „1.1 SAFETY RULES“ ON PAGE 5!

- a. Engage iron sights (chapter 4.6.1 on page 25).
- b. Load the Weapon (chapter 4.9.1 on page 30).
- c. Apply a proper firing position..
- d. Disengage Safety (chapter 4.2 on page 15).
- e. Pull the trigger until the shot is released.



Advice!	
	Refer to chapter „5.5 Functional check“ on page 46!

## 5. Maintenance procedures

Advice!	
	Do not pull the trigger on the disassembled firearm, as excessively empty trigger pulls may damage the lower receiver.



### 5.1 Scope of cleaning cycles

#### 5.1.1 Quick cleaning

The following steps are performed during Quick Cleaning:

1. Remove the lower receiver the weapon (see chapter “5.2 Disassembly” on page 33).
2. Remove the bolt from upper receiver.
3. Clean the bolt and the inside of the upper receiver with a cloth.
4. Lightly oil the inside of the upper receiver and the bolt.
5. Assembly (see chapter “5.4 Assembly” on page 40).
6. Functional check (see chapter “5.5 Functional check of the gun” on page 46).

## 5.2 Reassembly

### 5.2.1 Reassembly of the weapon

- Clear the weapon (chapter 4.1 on page 15).
- Close the bolt (chapter 4.7 on page 26).
- Press the front and rear take-down pin from left side to right side and pull it out from right side until the lower receiver comes loose.



- Separate the lower receiver from the weapon

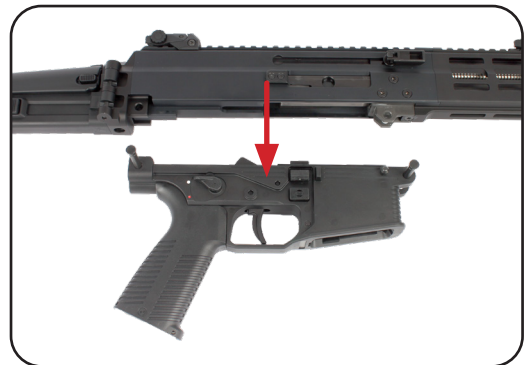

- Grasp the stock, press it down and pull it back out of the upper receiver.

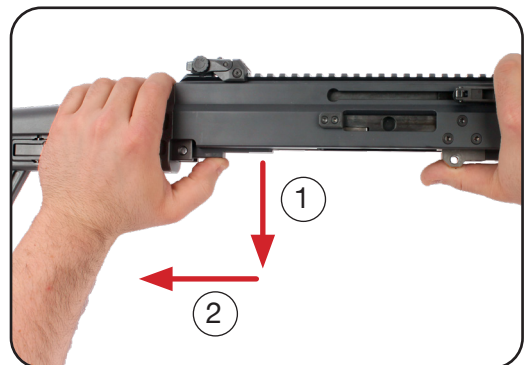

#### Advice!



The telescopic stock must be in extracted position for pushing out the rear take-down pin

- f. Pull the charging handle backwards until the recoil spring can be grasped, then pull the recoil spring backwards out of the upper receiver..

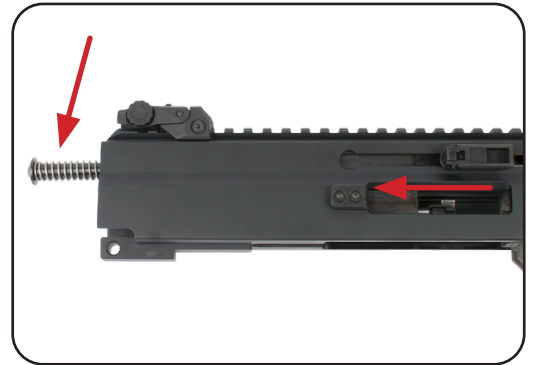

- g. Pull the bolt rearward out of the receiver and remove it.

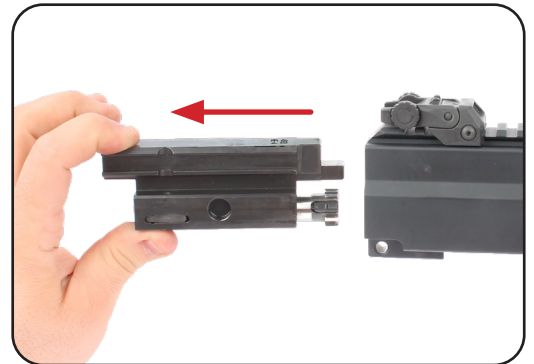

- h. Press the bolt head against the bolt carrier as far as possible. Make sure that the cam pin is in the center of the cutout on the bolt carrier (lengthwise and crosswise).

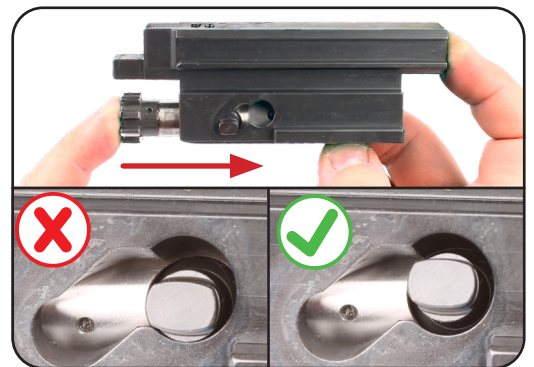

- i. Pull the cam pin out of the bolt carrier respectively the bolt head.

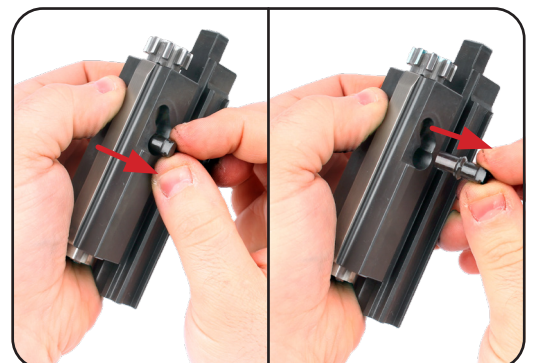

j. Pull the bolt head out of the bolt carrier.

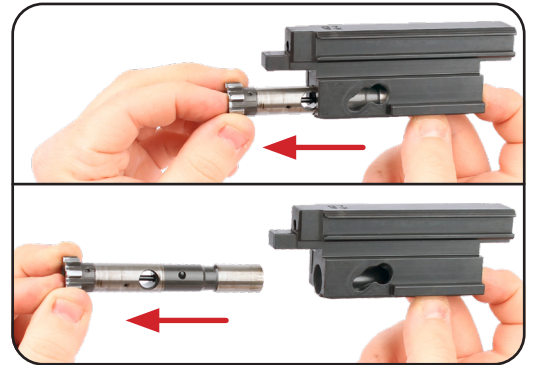

k. Place the bolt head on a hard surface, with the end where the firing pin protrudes, and press it down as far as possible.



l. Use a punch to push the locking bolt out of the bolt head.

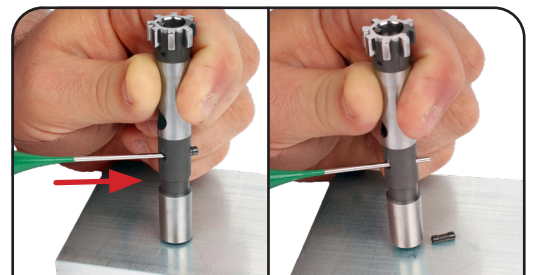

m. Carefully lift the bolt head until the tension on the firing pin spring is relieved.

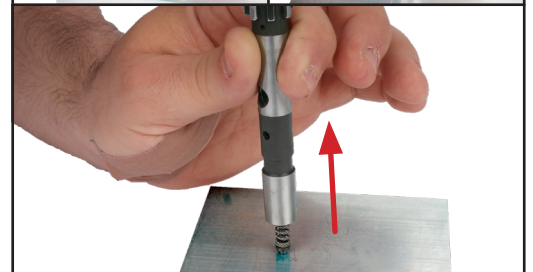

n. Pull the firing pin out of the bolt head.



o. Pull the firing pin spring of the firing pin.

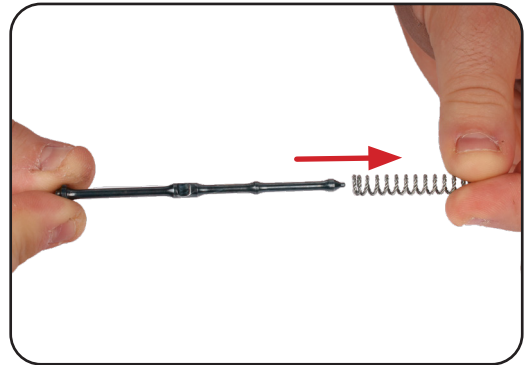

p. Push in the locking pin on the gas regulator using a punch and turn the gas nozzle 180°, starting from the home position, until it can be removed.

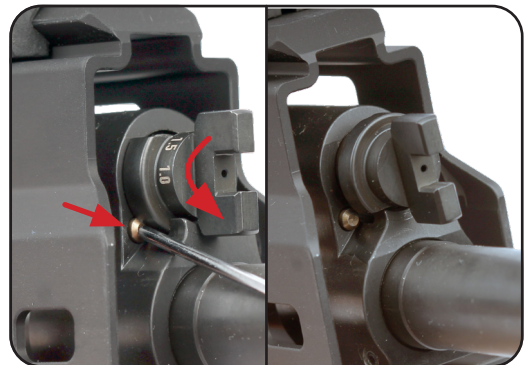

q. Pull the gas regulator, gas piston and gas rod forward out of the housing.

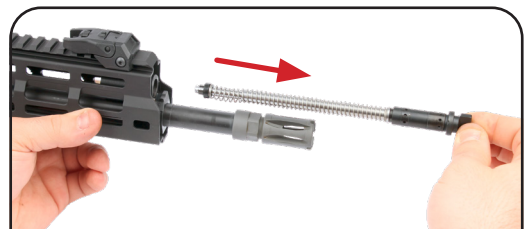

r. Remove the gas regulator from the gas piston.



s. Remove the gas piston from the gas rod.

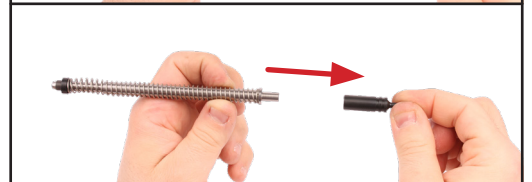

The weapon is now disassembled and ready for cleaning and inspections.



### 5.2.2 Disassembly upper receiver

- a. Pull the charging carrier backwards until the charging handles are congruent with the cutout in the receiver.

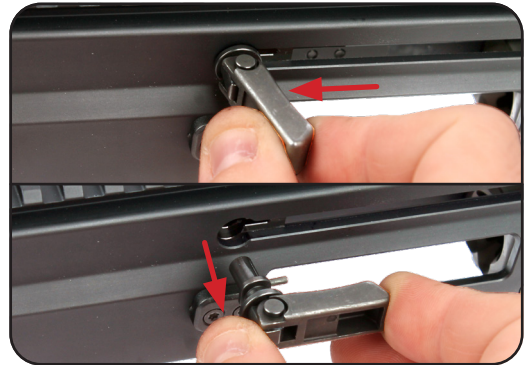

- b. Pull both charging handles sideways out of the receiver.

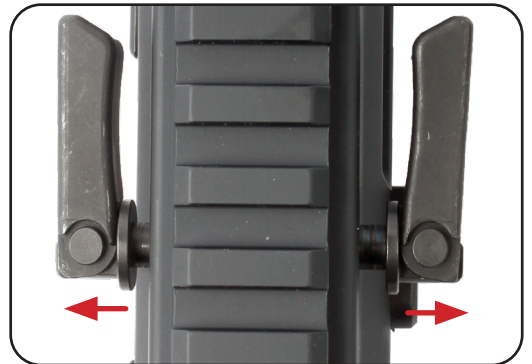

- c. Using the cleaning rod, push the charging handle carrier out of the receiver from below (handle side) to the rear.

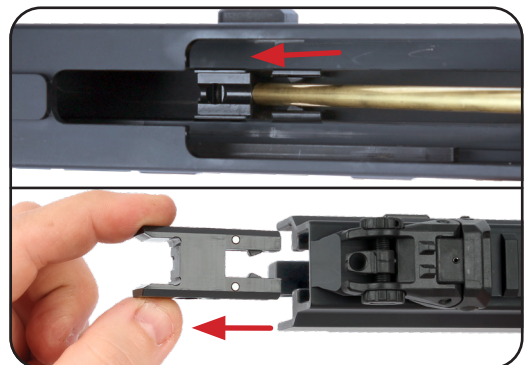

The upper receiver is now disassembled and ready for cleaning and inspections.

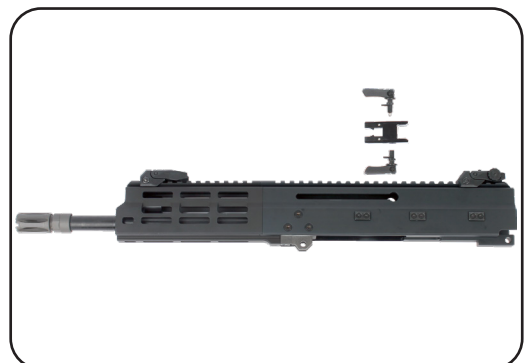

### 5.3 Cleaning and inspection

- a. Use a cleaning rod of suitable length with a copper brush to clean the barrel from the rear side.



- b. Clean the chamber with a short cleaning rod and a large brush.



- c. Using a small brush, clean the locking lugs on the bolt head, the bolt face and all guiding surfaces of the cam pin, bolt head and bolt carrier and then lubricate with a film of oil.

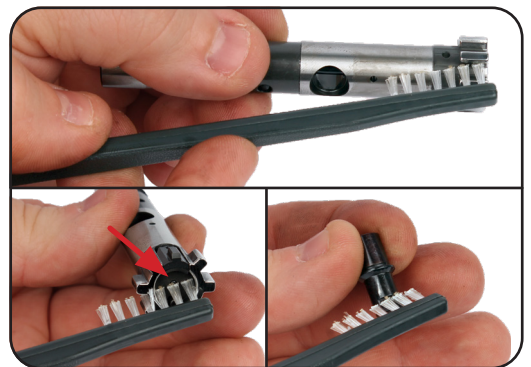

- d. Clean the parts of the gas system (gas piston, gas regulator and gas rod) with a brush and then lubricate them with a film of oil.



- e. Clean the parts of the firing pin (firing pin, firing pin spring and locking pin).



- f. Clean the upper and lower receiver with a small brush.
- g. Wipe all accessible areas with an oily cloth.



- h. Inspect all accessible parts by eye for cracks, deformation or other excessive wear.
- i. Lubricate all accessible surfaces of steel parts with a film of oil and protect them from rust.



<b>SAFETY ADVICE!</b>	
	<b>REPORT DEFECTS IMMEDIATELY!</b>

## 5.4 Reassembly

### 5.4.1 Reassembly of the weapon

- a. Reassemble the upper receiver (chapter 5.4.2 on page 45).
- b. Position the gas piston on the gas rod.

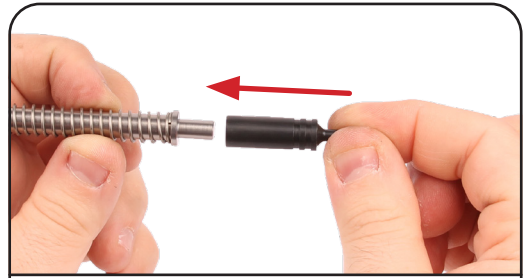

- c. Position the gas regulator on the gas piston.



- d. Slide the preassembled gas unit into the upper receiver.

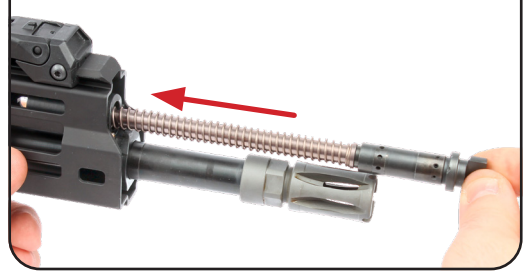

- e. Push in the locking pin with the help of a punch and turn the gas regulator by 180° until it engages in the home position.

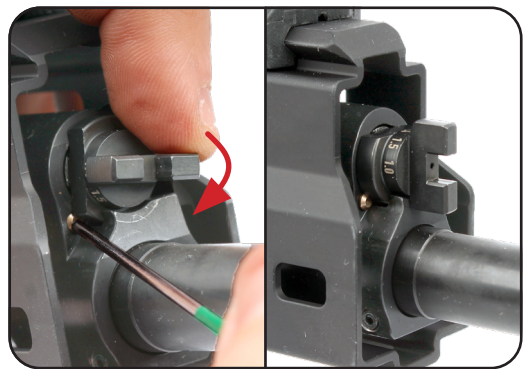

- f. Slide the firing pin spring on the firing pin and push it over the dome.

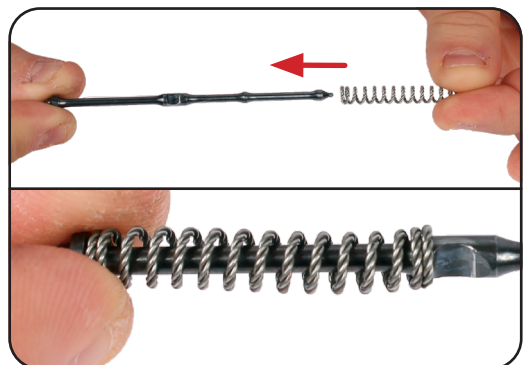

g. Insert the firing pin into the bolt head.

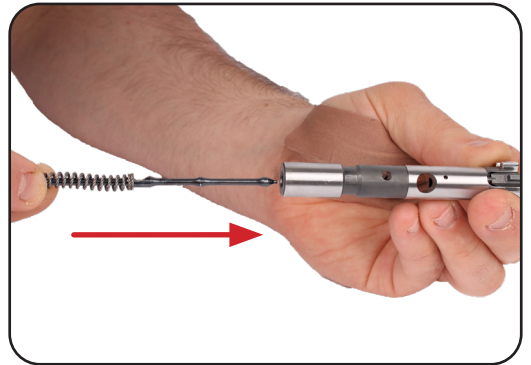

Advice!	
	The cutout in the firing pin and the hole for the locking pin in the bolt head must be oriented before inserting.

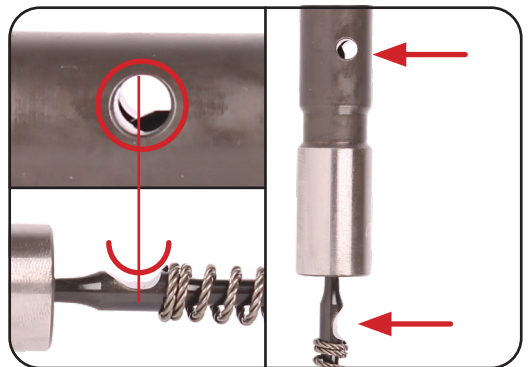

h. Place the bolt head on a hard surface, with the end where the firing pin protrudes, and press it down as far as possible.



i. Push the locking bolt into the bolt head until it audibly engages in the end position.



j. Insert the bolt head into the bolt carrier from the front.

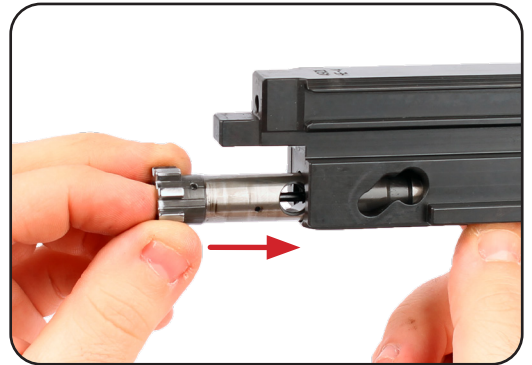

k. Align the bolt head in the bolt carrier so that the extractor is oriented at 09:00 (looking at the bolt head from the front).

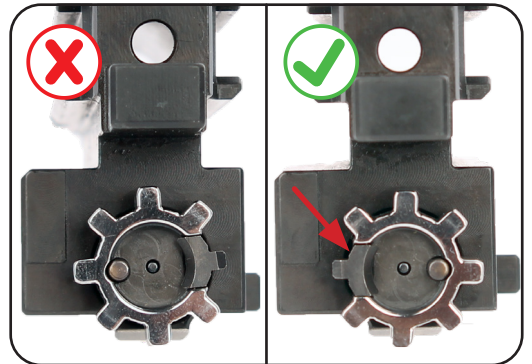

l. Press the bolt head against the bolt carrier as far as possible. Make sure that the hole for the cam pin is in the center of the recess on the bolt carrier (lengthwise and crosswise).

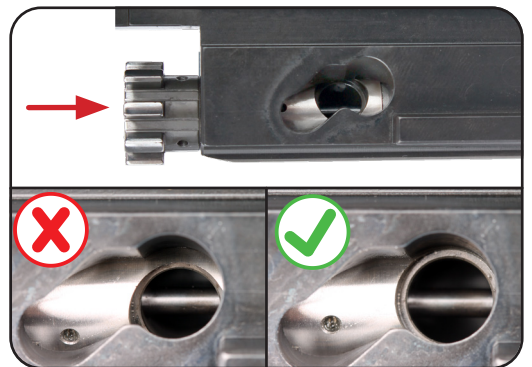

m. Insert the cam pin.



n. Push the bolt head out as far as possible (see illustration).

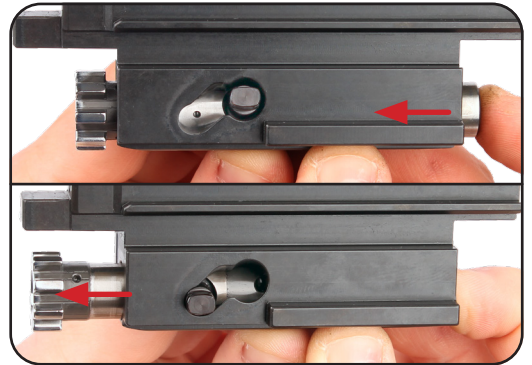

o. Insert the Bolt into the upper Receiver..

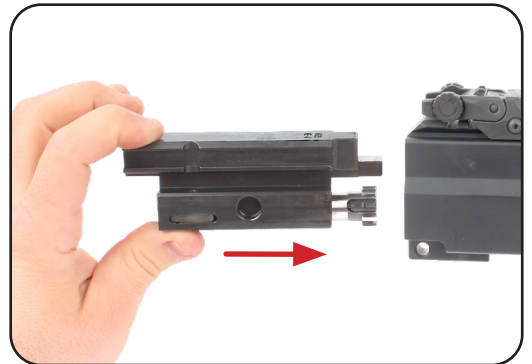

p. Insert the recoil spring into the housing.

<b>Advice!</b>	
<b>i</b>	Check the alignment of the recoil spring! Insert the recoil spring into the lock with the curved end first.

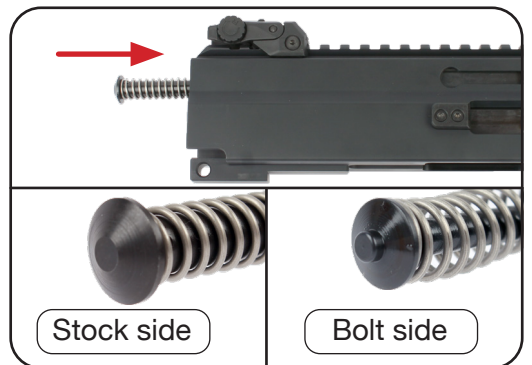

q. Insert the stock into the receiver and push it upwards.

<b>Advice!</b>	
<b>i</b>	The telescopic stock must be in extracted position.

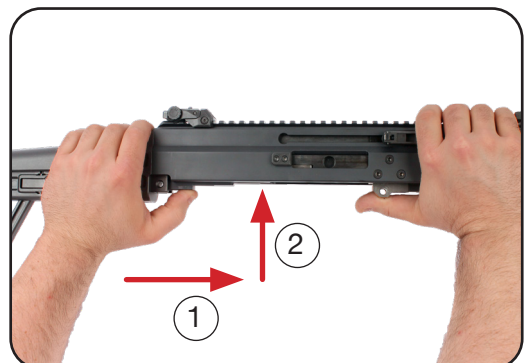

- r. Place the lower receiver on upper the receiver and push in the front and rear take-down pin from the right side.





- s. Execute a functional check (chapter 5.5 on page 46).

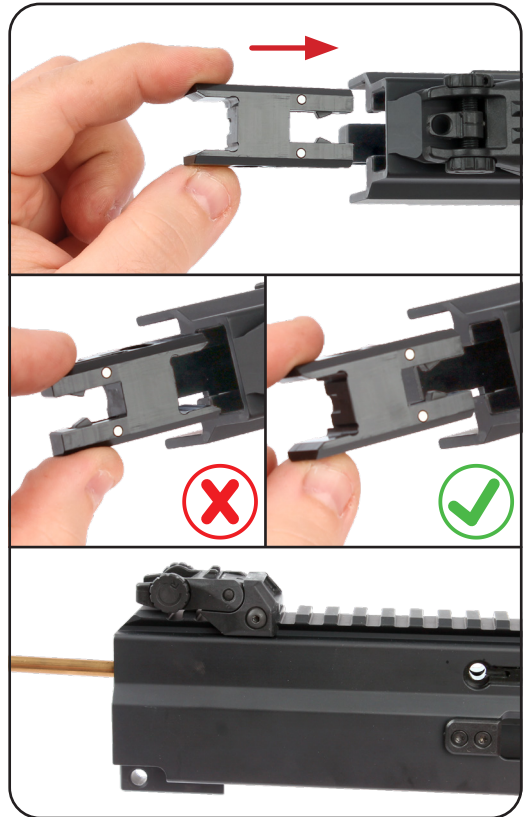

### 5.4.2 Reassembly of upper receiver

- a. Push the charging handle carrier into the upper receiver from behind.



Advice!	
	Ensure the correct orientation of the charging handle carrier!

- b. Push in the charging handle carrier, by using the cleaning rod, until it is congruent with the cutout for installing the charging handle

- c. Make sure to insert the charging handle in the correct orientation in order for the pin to slide into the recess in the charging handle carrier



- d. Insert both charging handles on the side and press them together.

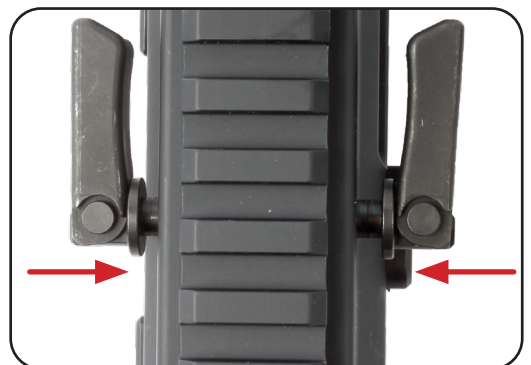

## 5.5 Functional check

- a. Clear weapon (chapter 4.1 on page 15).
- b. Push on right side bolt catch » bolt shall snap into closed position.
- c. Pull charging handle to its rearmost position and push bolt catch upward » bolt shall stay in open.
- d. Push on left side bolt catch » bolt shall snap into closed position.
- e. Engage safety and pull trigger » hammer shall not strike.
- f. Rotate right side fire selector to single fire position and back to safe position » shall snap audibly in both positions.
- g. Rotate left side fire selector to single fire position, pull trigger and hold » hammer shall strike audibly.
- h. Pull charging handle to the rearmost position and slide it to forward position. Release trigger and pull it again » hammer shall strike audibly.
- i. Engage safety, insert an empty magazine and pull downward » magazine retainer must hold securely.
- j. Pull charging handle to rearmost position and release » bolt shall stay open.
- k. Push left magazine retainer and pull magazine downward » magazine shall come loose.
- l. Reinsert empty magazine, push right magazine retainer and pull magazine downward » magazine shall come loose.
- m. Pull charging handle to the rearmost position and release » Bolt shall run to closed position. Repeat steps i to m with all available magazines.
- n. Engage sights » both shall audibly snap in open position and point straight upward.
- o. Close sights » both shall audibly snap in closed position
- p. Turn the gas regulator to the 3 positions » Gas nozzle should engage in each position (chapter 4.8.1 on page 27)
- q. Check extracting and retracting and locking mechanisms of installed stock for proper function (chapter 4.4 on page 17).
- r. Inspect installed accessories for function and tight mounting.

If any function fails, disassemble the weapon, check for defective parts, reassemble the weapon and check for correct reassembly. If the failure persists, refer to armorer.

## 5.6 Troubleshooting table

#	Observation	Immediate action
1	Inconsistent impacts	Control correct position and tight sit of the iron sights. Present weapon at first opportunity to armourer for inspection.
2	Failure to feed	Hold the bolt open with the bolt catch, remove the magazine, if there are still cartridges in the upper receiver, remove them. Insert the magazine, close the bolt by pressing the bolt catch. If the malfunction is repeated, use another magazine. If the malfunction persists, check the correct setting of the gas regulator (chapter 4.8 on page 27). If the malfunction persists, have the gun checked by an armorer or the manufacturer.
3	Failure to eject	Pull charging handle to rearmost position and observe for ejected shell or cartridge. Inspect barrel to be clear. Load a fresh cartridge. If the malfunction persists, check the correct setting of the gas regulator (chapter 4.8 on page 27). Present weapon for inspection of extractor and ejector to an armourer at the first opportunity.
4	Failure to strike	Hold the bolt open with the bolt catch and remove eventual obstructions captured in the upper receiver. Load a fresh cartridge. If failure repeats, clean weapon or present it to an armorer.
5	Failure to ignite	Wait 30 seconds with the muzzle pointing to a safe direction. Then pull charging handle to rearmost position and observe for ejected cartridge. Collect cartridge for later analyses. Load a fresh cartridge. Present weapon and ejected cartridge to an armorer at the first opportunity.
6	Heavy recoil	Check the correct setting of the gas regulator (chapter 4.8 on page 27).

### Advice!



Failure reports to the manufacturer must include the serial number of the weapon, the type of ammunitions, the history of the failure and the history of the attempted corrective actions. The report can be sent to B&T by E-Mail along with pictures

## 6. Accessories

### 6.1 Suppressors

Picture	Art.-No.	Type	Description
 A cylindrical, light grey suppressor with a black mounting bracket at one end and a small circular opening at the other.	SD-123029 SD-123033	APC223 APC308	Suppressor ROTEX-X
 A cylindrical, light grey suppressor with a black mounting bracket at one end and a larger circular opening with multiple internal ports at the other.	SD-122812 SD-122835	APC223 APC308	Suppressor RBS QDN

## 6.2 Stocks / Adapters

Picture	Art.-No.	Type	Description
	BT-361639 BT-361640	APC223/300 APC308	Fold- retractable stock PRO (Standard)
	BT-361496 BT-361502	APC223/300 APC308	Foldable stock
	BT-20407 BT-20554	APC223/300 APC308	Telescopic stock
	BT-361498 BT-361504	APC223/300 APC308	Helmet stock
	BT-361497 BT-361505	APC223/300 APC308	Fixed stock

Picture	Art.-No.	Type	Description
	BT-361501 BT-361507	APC223/300 APC308	M4 Adapter Foldable
	BT-361500 BT-361506	APC223/300 APC308	Pistol adapter
	BT-361557 BT-361557	APC223/300 APC308	NAR-Adapter
	BT-20526 BT-20530	APC223/300 APC308	Telescopic Brace Adapter

### 6.3 Magazines

Picture	Art.-No.	Type	Description
	MA-MAG556-BLK MA-MAG559-BLK	APC223	Magazine 30 rounds Magazine 10 rounds
	BT-361173	APC300	Magazine 30 rounds
	MA-MAG292-BLK BT-36846 MA-MAG290-BLK	APC308	Magazine 25 rounds Magazine 20 rounds Magazine 10 rounds
	BT-300696	APC9	B&T bumper pad for magazine PRO
	BT-300698	APC9	B&T magazine upgrade kit with rubber bumper for old B&T magazines
	MA-MAG595	APC223	Magazine clamp

## 6.4 Flashlights

Picture	Art.-No.	Description
	BT-WML-B-W-L-GEN2	B&T Weapon Mounted Light GEN-2

## 6.5 Brass catcher

Picture	Art.-No.	Description
	BT-22438	Brasscatcher

## 6.6 Grips

Picture	Art.-No.	Description
	BT-231227-BK	Angled fore grip 45° picatinny rail attachment
	BT-211564-BL	Unigrip QD short
	BT-21840	Unigrip QD

## 6.7 Sights

Picture	Art.-No.	Description
	AP-11830-BT-QD	Aimpoint® sight Micro T-1 black - NVD compatible, 4 MOA, ACET technology - with B&T QD NAR mount
	AP-200709	Aimpoint® sight Micro T-1 black - NVD compatible, 2 MOA, ACET technology - with 39 mm spacer mounted (bulk packed)

## 6.8 Maintenance

Picture	Art.-No.	Type	Description
	SC-64B_5.56 SC-64B_7.62	APC223 APC300/308	Barrel brush (bronce)
	SC-64M_5.56 SC-64M_5.56	APC223/300 APC308	Chamber brush (bronce steel)
	SC-AR15_5.56_8-32 SC-TR/M_7.62_8-32	APC223 APC308	Putzzeug

## 7. Warranty statement

Warranty claims on behalf of the Client are to be explicitly declared as such. During the legal warranty period, B&T provides warranty cover solely for defects that arise as a result of faulty materials, construction errors or poor workmanship. If a warranty claim is justified, B&T will, at its own discretion, either repair or replace the defective good. Costs incurred in transporting the defective good to B&T are borne by the Client. Spare parts fitted and replaced become the property of B&T.

Inasmuch as is legally permitted, any other liability of B&T is excluded, in particular liability for damages arising either directly or indirectly from the delivered good itself, from its use or from its defects.

Merchandise is covered by the warranty provisions of the manufacturer. Parts that are naturally subject to wear and tear, damage arising from insufficient maintenance work, noncompliance with operating regulations and cases of force majeure are all excluded from warranty cover. Warranty claims lapse if the Client itself or third parties alter or repair the delivered good without the prior written consent of B&T. All product specifications are subject to change without prior notice. Published data are mean values and therefore not suitable acceptance criteria.

The manufacturer:

B&T AG - 3608 Thun - Switzerland

Phone +41 33 334 67 00

E-mail: [info@bt-ag.com](mailto:info@bt-ag.com)