

Military Assault Rifle
Operator Manual

STG4

WARNINGS

- Never Point any weapon, loaded or unloaded, at anything you do not intend to shoot.
- Load and Unload with the muzzle pointed in a safe direction.
- When receiving a firearm always check that it is unloaded.
- Never put your hand over the muzzle of the weapon.
- Don't try to change your firearms' trigger pull, because alteration of trigger pull usually affects sear engagement and may cause accidental discharge.
- If there is any reason to suspect that a bullet is obstructing the barrel, have it immediately checked by the unit armorer.
- Keep your finger off the trigger until you are actually aiming at the target ready to shoot.
- Always clear weapons before entering a place where there are people.
- Old or reloaded ammunition may be dangerous. We recommend against using it.
- If the barrel is very hot from firing there is a risk of Cook-Off (That is, a round in the chamber discharging by absorbing heat from the barrel). A Cook-Off can occur at any time after chambering a round in a very hot barrel. When this condition is suspected the chamber must be cleared immediately after firing.
- Do not attempt fire if water is in the barrel from forcging.
- Always be aware of possible risk from dropping your weapon. Some parts of the mechanism could be damaged. You may not see the damage, but if it is severe, the firearm may discharge and cause injury, death or damage to property. If your weapon as been dropped, have it checked by the unit armorer.

- Keep clear and keep others clear of the ejection port. Spent cartridges are ejected with enough force to cause injury, and the ejection port must be unobstructed by your hand to insure safe ejection of live rounds. Never place fingers in ejection port; they could be burned by hot metal or injured by the bolt moving forward.
- Never dry fire your weapon when the receivers are open and do not alter parts as the level of safety could be reduced.
- Firearms and alcohol or drugs don't mix. Do not handle a weapon after consuming any kind of alcohol, medications or drugs that may affect your ability.
- Always treat every weapon as if it was loaded.

Operator:

Rank:

Corp:

Unit:

Weapon Serial Number:

Weapon Model:

Weapon Caliber:

Place and Date:

Signature:

TABLE OF CONTEST

7.....	Illustration of Weapons	32.....	Functional Checks
8.....	Description and Characteristics of Weapons	37.....	Malfunction and trouble Shooting
9.....	Firing Characteristics	44.....	Field Sight
10.....	Operating Features	46.....	Loading
13.....	Maintenance	48.....	Aiming and Firing
14.....	Field Stripping	50.....	Unloading
16.....	Bolt and Bolt Carrier	52.....	Stoppage and Immediate Actions
18.....	Buttstock	53.....	Dangerous Situations
20.....	Maintenance Cleaning Procedures	55.....	Water in the Barrel
24.....	Lubrication	56.....	Exploded View and Part List
26.....	Assembly	66.....	Warranty
30.....	Lower Receiver		

ILLUSTRATION OF WEAPON

STG4 COMMANDO 10.5"

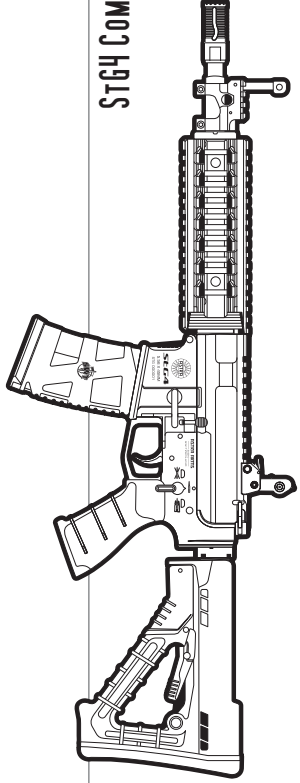

STG4 COMMANDO GL 12.5"

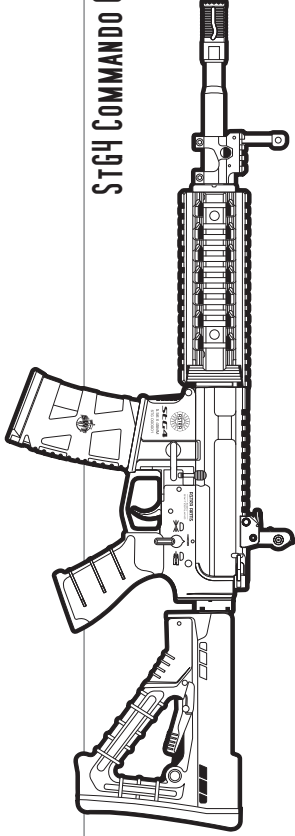

STG4 CARBINE 14.5"

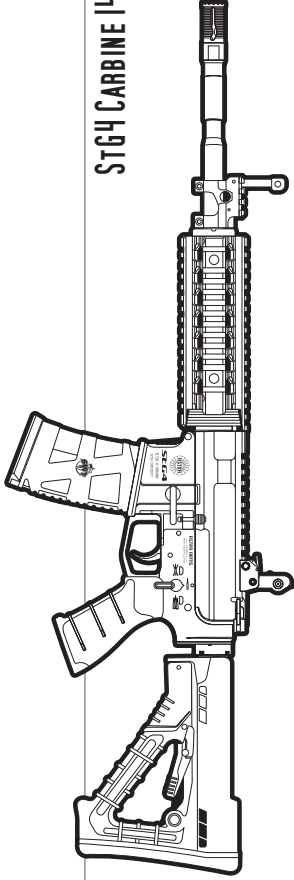

STG4 CARBINE L 16"

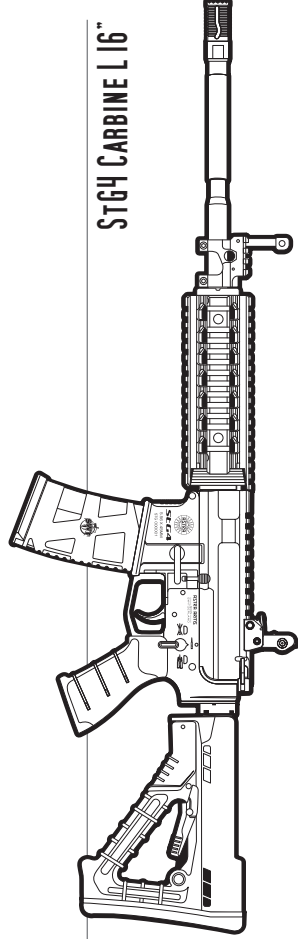

DESCRIPTION

This operator's manual describes the followings weapons and includes information on some features which may be included with variations of them.

StG4 Carbine L 16"

StG4 Carbine 14.5"

StG4 Commando GL 12.5"

StG4 Commando 10.5"

They are lightweight, air cooled, magazine fed weapons with telescoping buttstocks. They are capable of Automatic, Semiautomatic or 3 rounds Burst control fire. Are easily opened to expose the working parts for inspection and cleaning.

An M203 Grenade Launcher may also be installed on 16", 14.5" and 12" barreled weapons.

CHARACTERISTICS OF WEAPONS

- Gas Operated
- 5.56x45mm Caliber
- Air-cooled
- Polymer Magazine
- Semiautomatic, Automatic or 3-Rounds Burst control
- Flat Top Upper Receiver
- Foldable Rear Sight
- Foldable Front Sight
- Handguard with Picatinny Rail Integrated
- Telescoping Buttstock

FIRING CHARACTERISTICS

- Cyclic Rate of Fire: 700-1000 rounds per minute. (Theoretical number of rounds which could be fired full auto in one minute).

- Rate of Fire: Semiautomatic: 45-65 rounds per minute. (Number of rounds which could be fired in one minute with selector on "Semi", depend on operator's dexterity and time needed to replace magazines)

Burst or Auto: 150-200 rounds per minute. (Numbers of rounds which could be fired in one minute with selector on Burst or Auto including time to replace magazines)

Sustained: 12-15 rounds per minute. (Recommended number of rounds which can be fired every minute for extended periods.

With the 1 in 7 inch twist in the rifling of the StG4 Carbines and Commandos weapons, either M193 or M855 ammunition may be fired. Muzzle velocity, muzzle energy, and maximum effective range will vary with barrel length and ammunition used. Using M855 ammunition muzzle velocity will be reduced, while muzzle energy and maximum effective range are increased for carbine.

AMMUNITION	5.56x45mm M193	5.56x45mm M855-SS109
MUZZLE VELOCITY	Meter per Second	Meter per Second
CARBINES	930	875
COMMANDOS	884	796
MUZZLE ENERGY	Joules	Joules
CARBINES	1573	1540
COMMANDOS	1391	1272

OPERATING FEATURES

“Operating Features” tells you the names of the parts and describes their function.

1 - Charging Handle: Retract bolt carrier.

2/4 - Sights: Used to align weapon with target. Rear Sight (2) is foldable and adjustable for windage. Front Sight (4) is foldable and used to adjust elevation. The weapon has sight rail (2) built on the upper receiver which an optical sight can be secured. The upper receiver has T Markings to show locations for mounting accessories. The markings allow the user to safely place the accessory back in the same location it was installed on before remove in being removed.

3 - Handguard: Is an aluminum handguard which protects the operator from the heat of the barrel. On the slots at 3,6,9 and 12 o'clock it is possible to install accessories like vertical grips, sling attachments, lights, lasers, magnifiers or night vision devices .

5 - Compensator: Reduce muzzle flash, helps keep muzzle from rising during firing, protects the muzzle and reduces signature when firing prone.

6 - Ejection Port Dust Cover: Keeps dirt and dust out of the chamber. When bolt carrier moves forward or rearward cover opens automatically.

6a - Deflector: Deflects cartridges clear of left handed operators.

7 - Magazine: 30-Round capacity.

8 - Magazine Release Button: Releases magazine for removal.

9 - Forward Assist Assembly: Provides a means of pushing bolt carrier forward when bolt fails to close and lock.

Note: *When you have to use the Forward Assist is time to clean your weapon.*

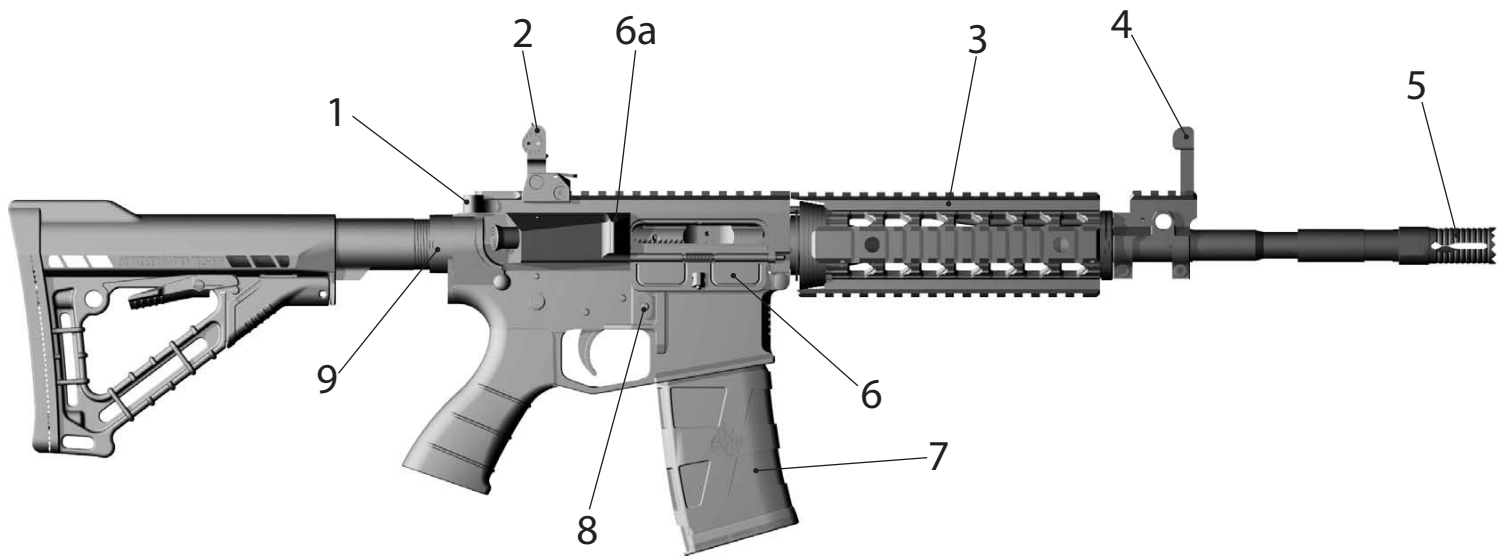

10 - Bolt Catch: Holds bolt carrier in open position

11- Selector Lever: Selects

AUTO - Full Auto

SEMI - Semiautomatic Single Shot

SAFE - Trigger Locked

BURST - 3 Rounds Auto Burst

SEMI - Semiautomatic Single Shot

SAFE - Trigger Locked

12- Buttstock: Sliding buttstock extends for shoulder firing, retracts for close combat and storage

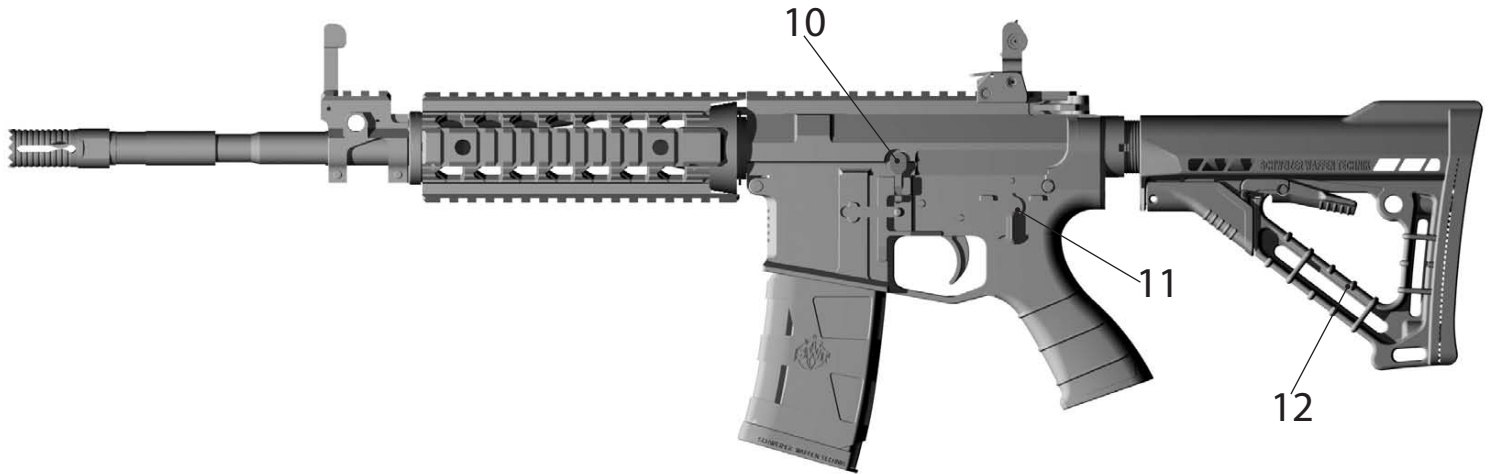

MAINTENANCE

The maintenance instructions explain to the operator how to field strip clean, lubricate, assemble and do a functional check on the weapon. A table at the end of this section deals with malfunctions and troubleshooting.

Tools Required:

- Cleaning Rod (Carbon Fiber or Flex Cable)
- 5.56mm Bore Brush
- 5.56mm Chamber Brush
- 5.56mm Patch Holder
- Flannel Patches

Materials Required:

- Lubricant Oil (Teflon or equivalent)
- Bore Cleaning Fluid

Note: If weapon has been used in salt air, water, mud, or sand it must be given to an armorer for complete disassembly, cleaning and inspection.

FIELD STRIPPING

Caution: unload before field stripping

- 1** - Press magazine release button (8) and remove magazine (7).
- 2** - Pull charging handle (1) to rear, check that the chamber (15) is empty, release charging handle.
- 3** - Ensure bolt is fully forward, push left end of takedown pin (13) into receiver. Pull pin to right until stopped by detent. Open Receivers.
- 4** - Pull charging handle about 8cm. rearward, remove bolt carrier (14)
- 5** - Remove charging handle by pulling down and to the rear.

Note: If there is any accessory, installed on the upper receiver, remove it.

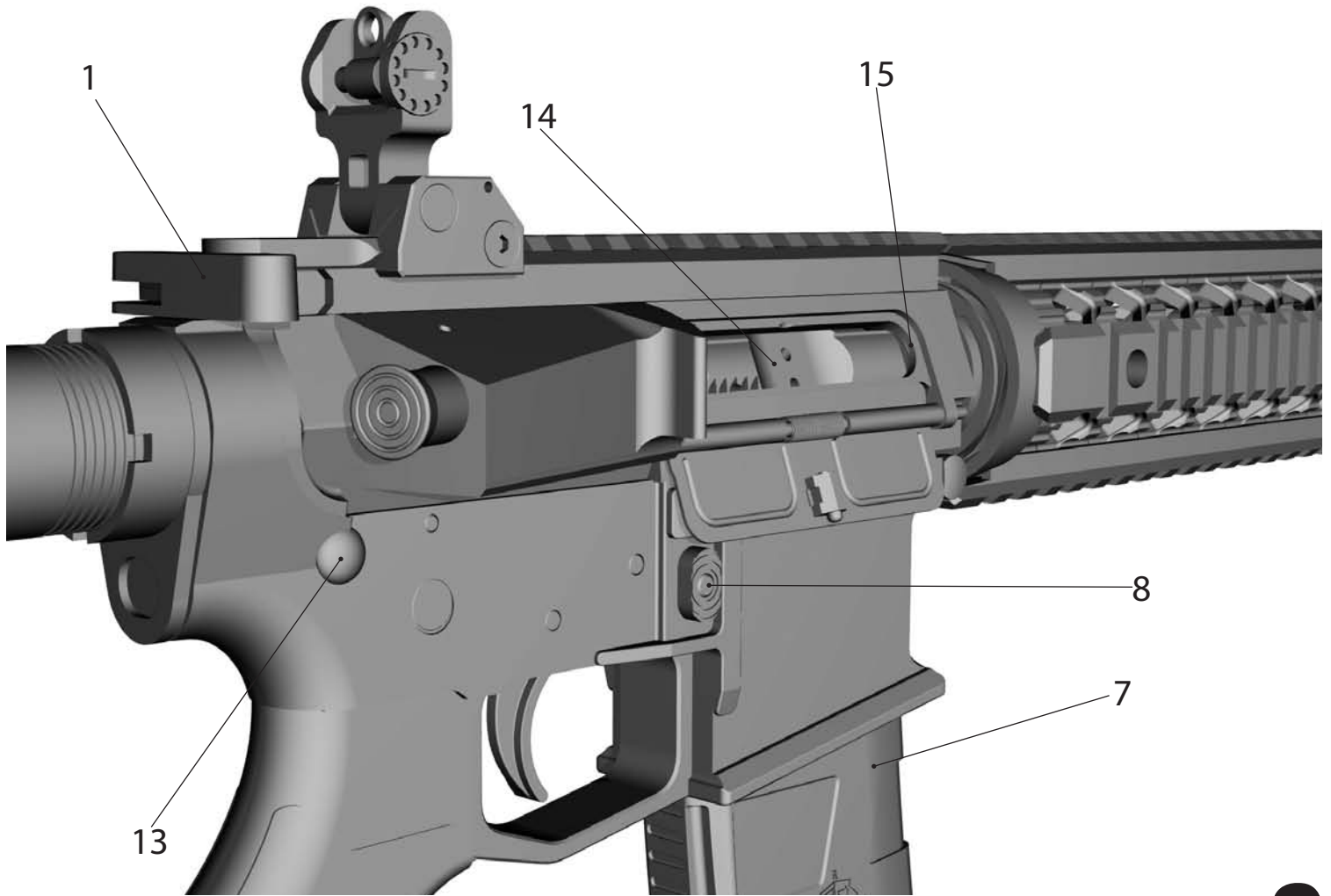

BOLT AND BOLT CARRIER

- 1a.** Push out firing pin retaining pin (17)
- b.** Drop our firing pin (16), through back of bolt carrier.
- c.** Rotate bolt (21) to right until cam pin (18) is clear of bolt carrier key (26). Rotate cam pin ¼ turn and remove. Pull bolt (21) from bolt carrier (14).
- d.** Hold the extractor (20) down to control the spring tension, carefully push out extractor pin (19). Do not remove extractor spring from extractor.

1. Push pivot pin (27) to right and pull out detent. Separate receivers. (Receivers need not be separate for routine cleaning).

2. With hammer (22) in cocked position push buffer (23) rearward
With hammer (22) in cocked position push buffer (23) be rearward

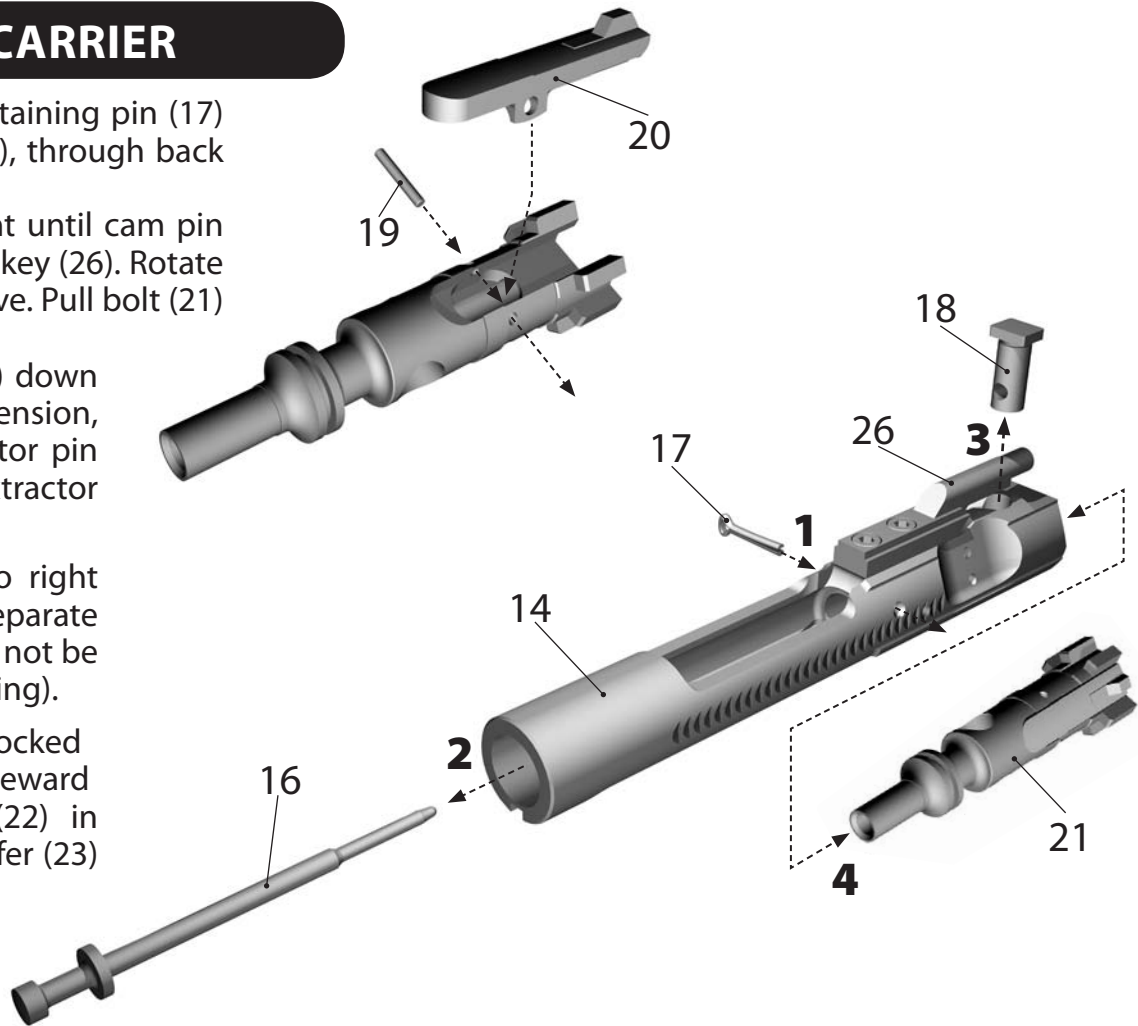

BOLT AND BOLT CARRIER ASSEMBLY

CARBINE & COMMANDO WEAPONS

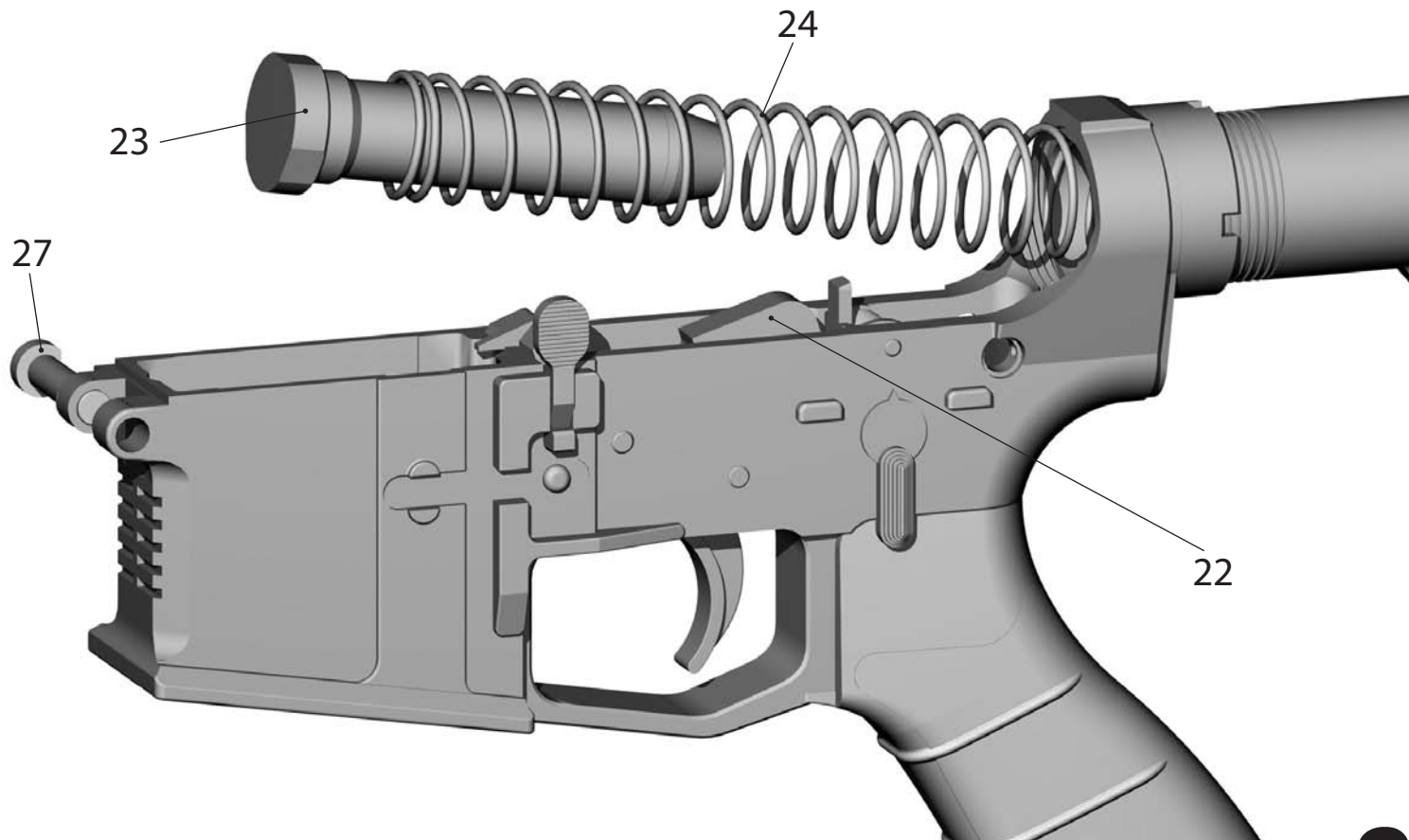

Buttstock

1 - Continue to hold buffer against spring tension, press hammer (22) down just enough to remove buffer (23) and action spring (24).

2 - Squeeze buttstock lever (30) and extend buttstock (12). Push lever down and pull buttstock of receiver extension (31).

3 - Position Upper Receiver (29) so that muzzle points up and other end rests against a solid base. Pull handguard slipping (28) down until it clears handguard. Remove handguard by pulling them out and down.

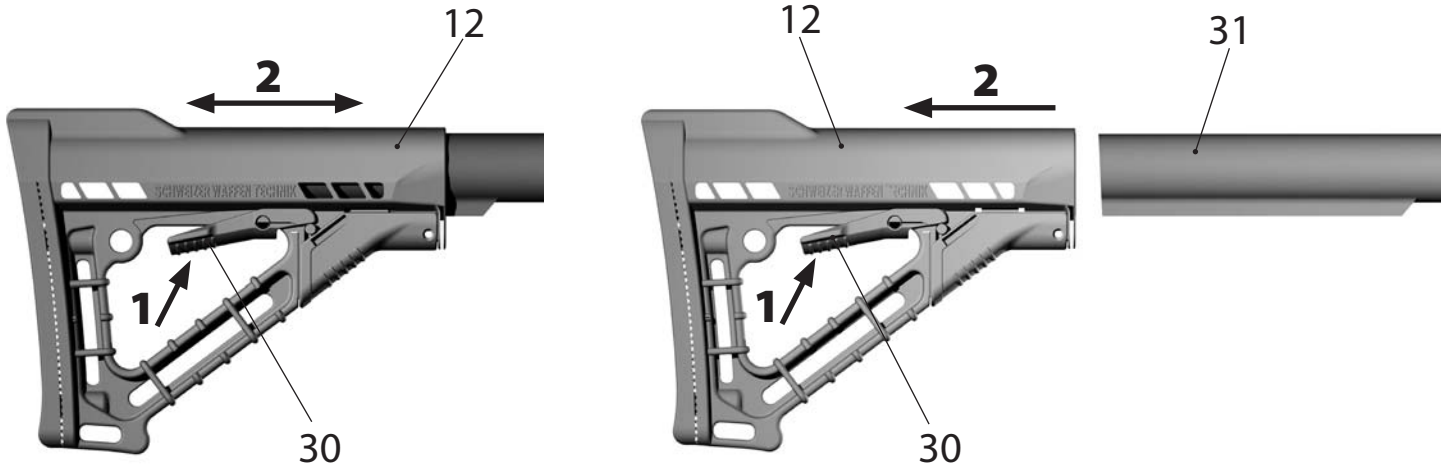

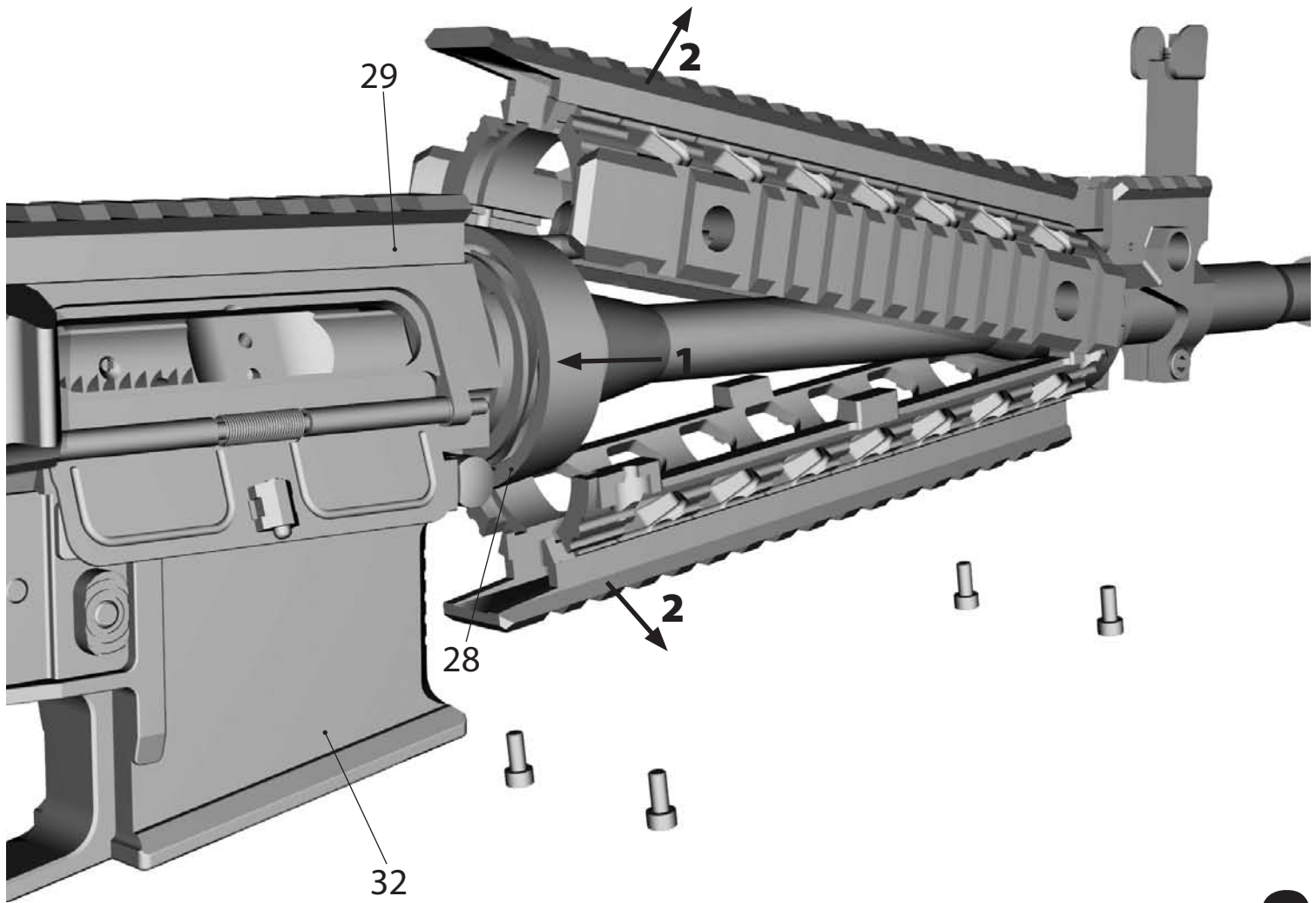

MAINTENANCE

Cleaning Materials

Cleaning and lubrication should be performed according to instructions in this manual, using a good grade of cleaner and lubricant.

The use of combination cleaner/lubricants while more convenient to use, may require more frequent applications than when using Teflon lubricating oil, and are recommended for use only under normal conditions. For maximum reliability of the weapon under heavy firing schedules or under adverse conditions, lubrication with Teflon lubricating oil is recommended.

Cleaning Procedure

1- Use clean dry bore cleaning brush to clean bolt carrier key (26). Insert brush into bolt carrier key (26) and rotate brush to remove carbon and powder residue.

2 - Apply 4 drops of bore cleaning fluid to the bore cleaning brush and use the brush to clean the bolt (21). Also clean the following parts:

- Gas rings (33)
- Rear face of bolt (21a & 21b)
- Face of extractor (20)
- Firing pin (16)

Note: *Do not attempt to remove heat discoloration from bolt carrier.*

1 - *Install patch to patch holder, apply 4 drops of bore cleaning fluid and clean bolt carrier (14) inside and out.*

2 - Use a cleaning cloth to wipe the bolt and the bolt carrier.

3 - Install the chamber brush on the cleaning rod and apply a few drops of bore cleaning fluid to the brush.

4 - Push the brush into the chamber (15) and rotate several times to clean the chamber. Then plunge the brush straight in and out of the chamber several times to clean between the locking lugs.

5 - Remove the chamber brush from the cleaning rod.

6 - Attach the bore brush to a cleaning rod. Apply a few drops of bore cleaning fluid to the brush and be careful to avoid rubbing the cleaning rod on the muzzle because accuracy will be affected.

Note: Do not move brush back and forth while it is in the barrel because the brush will stick.

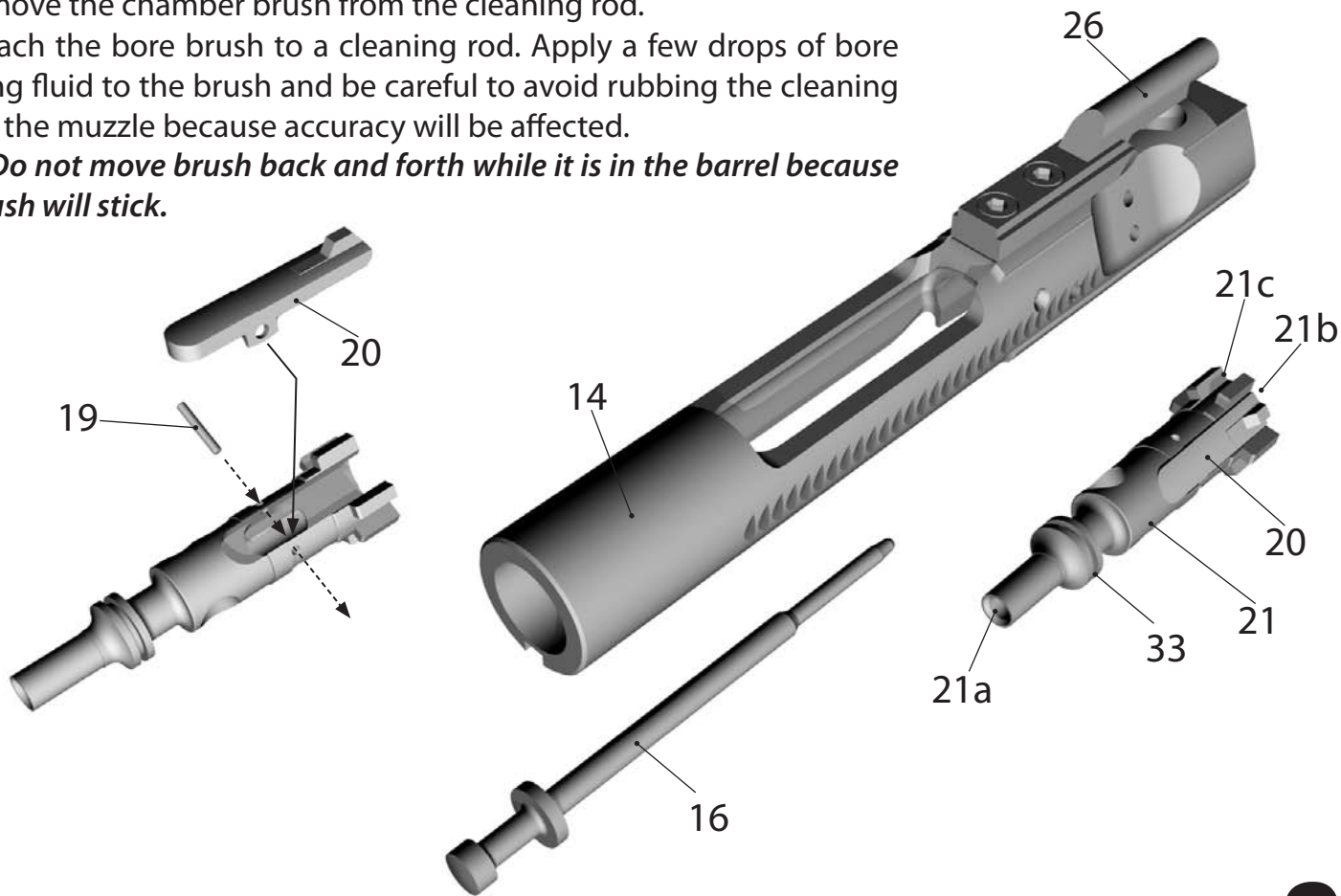

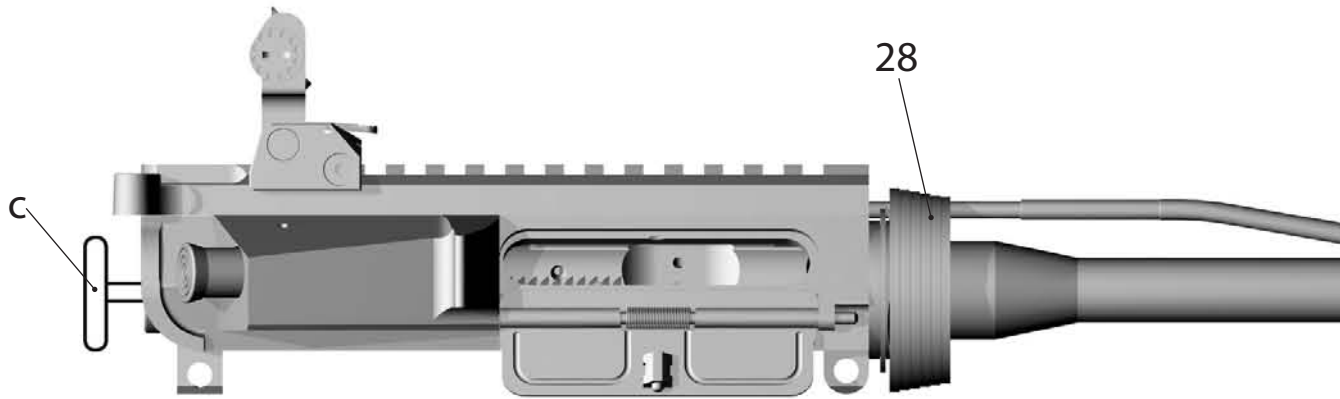

- 1** - Push the brush through the entire length of the bore from the chamber to the end. Pull the brush back through the entire length of the bore.
- 2** - Repeat step 1 three times.
- 3** - Remove the brush from the cleaning rod. Install the patch holder on the cleaning rod.
- 4** - Push rod and patch through the entire length of the bore. Pull the rod back through the entire length of the bore.
- 5** - Install a clean patch in holder and repeat step 4 until the clean patch come out of the bore clean and dry.
- 6** - Using a patch lightly oiled with Teflon lubricant or equivalent, wipe the buffer (23), the action spring (24), and the lower receiver (32) and remove any dirt.
- 7** - Clean the inside of the lower receiver (32) and around its assembled parts with the dry paint brush.
- 8** - Clean the receiver extension (31) with a dry cloth.
- 9** - Clean the buttstock (12) with a dry cloth, inside and outside.

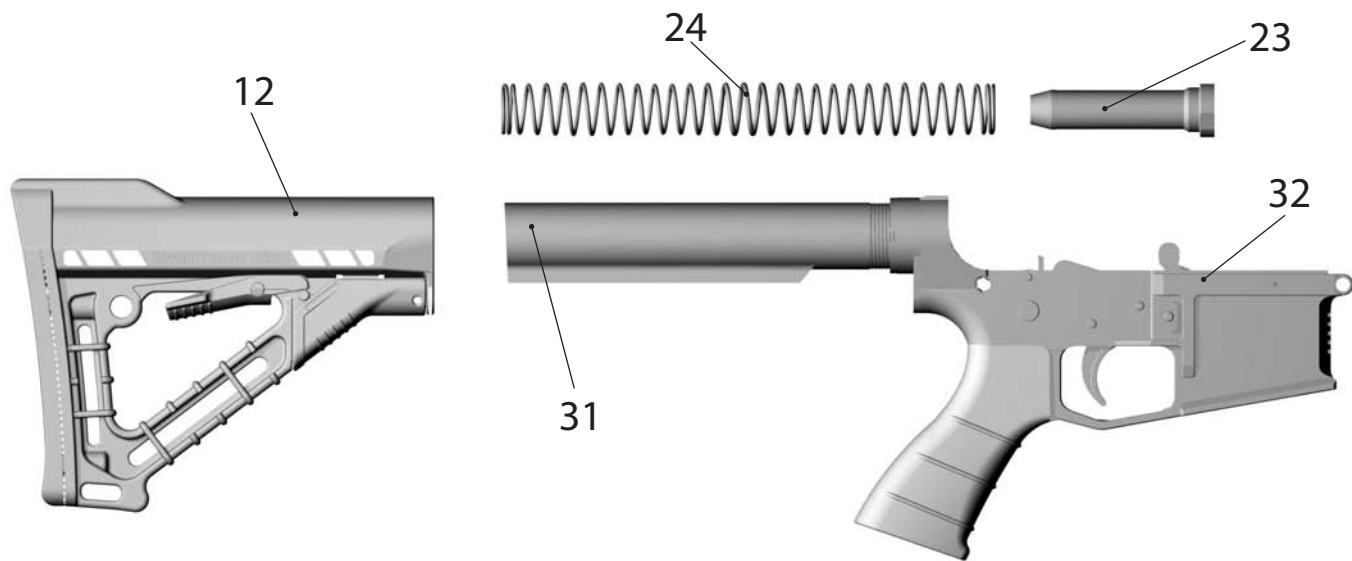
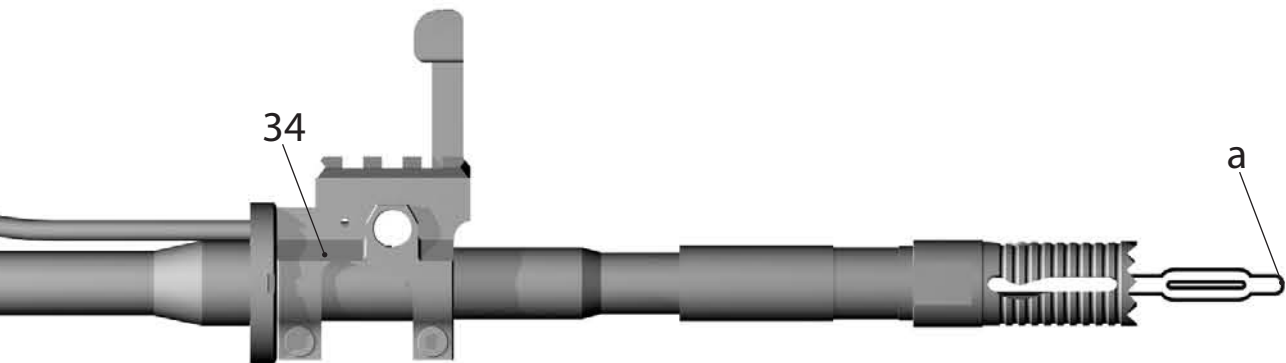

Lubrication

- 1 - Install the patch holder on the cleaning rod and insert a lightly oiled patch. Push the cleaning rod through the full length of the bore. Pull the rod from the bore. Make sure that the chamber remains dry.
- 2 - Using a lightly oiled patch wipe the outside of the barrel from the handguard cap (34) to the handguard slip ring (28).
- 3 - Wipe one drop of oil on each bolt/bolt carrier track (14a).
- 4 - Place one drop of oil in each bolt carrier hole (14b) and in the open end of the bolt carrier key (26).

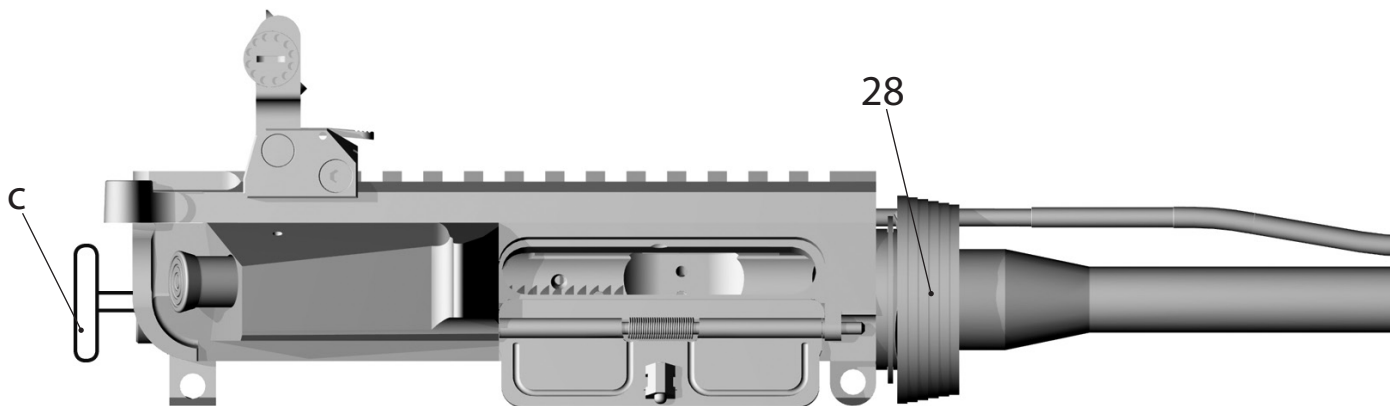

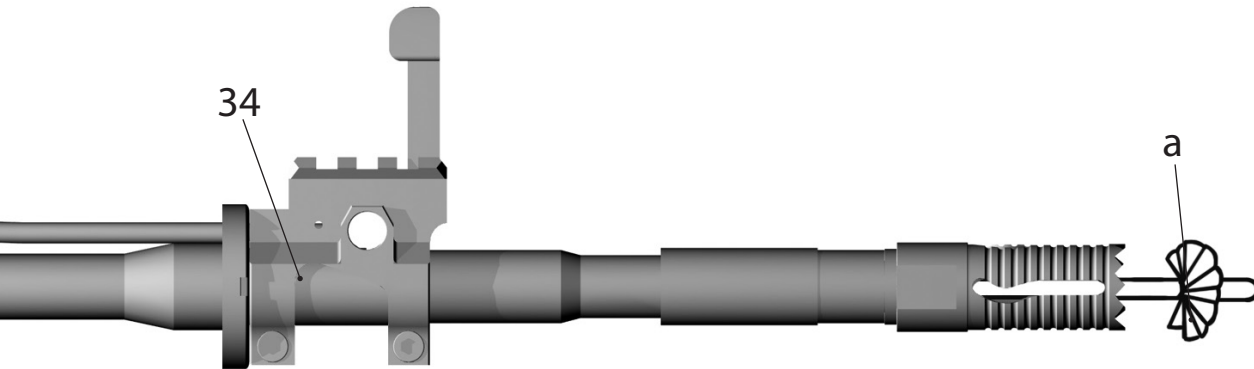
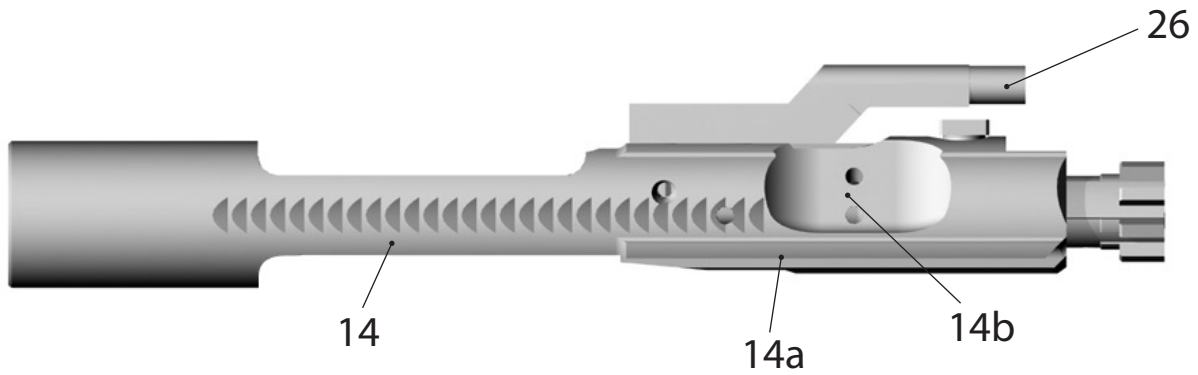

Assembly

1 - To assemble the bolt (21), first look at the under side of the extractor (20) and ensure the rubber insert (20a) and the extractor spring (20b) are in place. They should not have been removed from the extractor. If they are not in place they must be installed properly by an armorer, as shown in the illustration. Place the extractor assembly on bolt (21).

2 - While holding the extractor assembly (20) in place on bolt (21), insert the extractor pin (19) through the bolt and the extractor.

3 - With the bolt (21) oriented to the bolt carrier (14), as shown in the sketch insert the bolt in the bolt carrier.

4 - Align cam pin hole in bolt with end of the cam slot in the carrier furthest offset from the carrier key (26).

5 - Insert the cam pin (18) and rotate $\frac{1}{4}$ turn the pin.

6 - Rotate the bolt (21) until the cam pin (18) is under the bolt carrier key (26).

7 - Insert the the firing pin the (16) through the rear of the bolt carrier (14) and assemble firing pin to the bolt (21). Push the firing pin fully forward in the bolt and install the firing pin retaining pin (17).

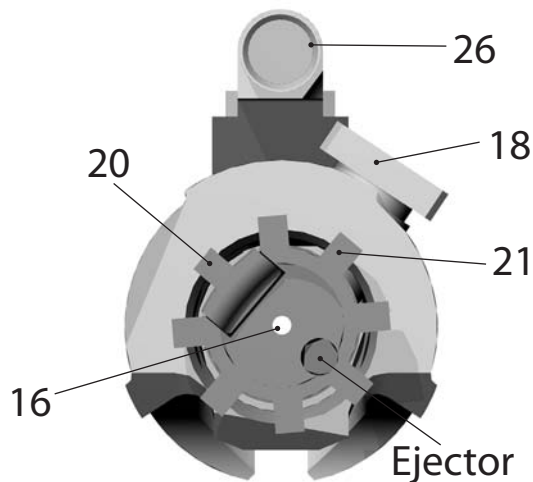
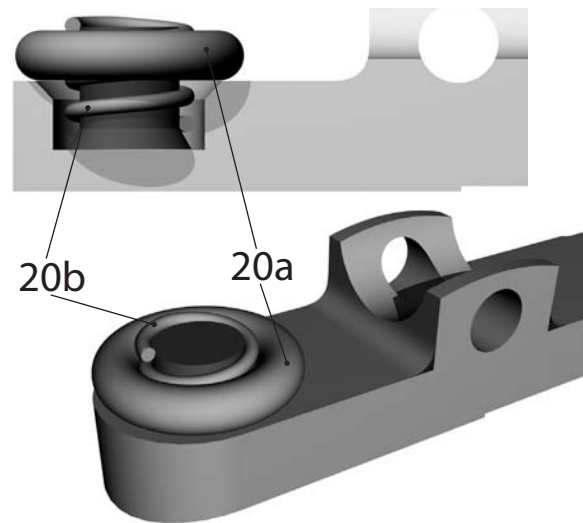

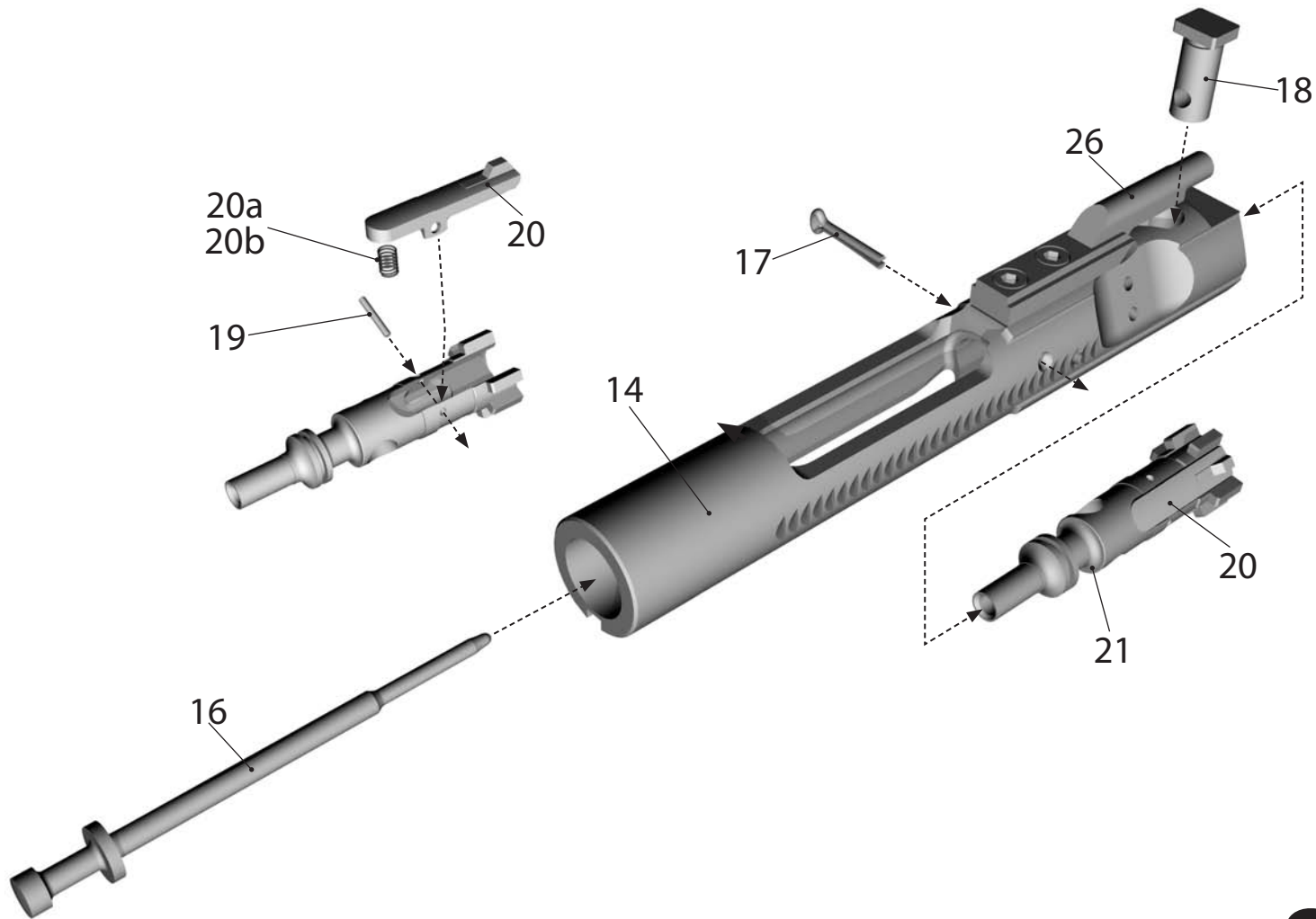

- 1** - Position the upper receiver (29) with the muzzle up and the other end against a solid base.
- 2** - Push forward ends of handguard (3) up into the handguard cap (34).
- 3** - Pull the sliping (28) down until the lower ends of the handguard clear the sliping. Release the sliping over the ends of the handguard to retain them.
- 4** - Place the charging handle (1) in the upper receiver (29). Push the charging handle forward until 8cm from the full forward position.
- 5** - Place the bolt carrier key (26) in the slot of the charging handle (1). Push forward on the bolt carrier and the charging handle until fully closed.

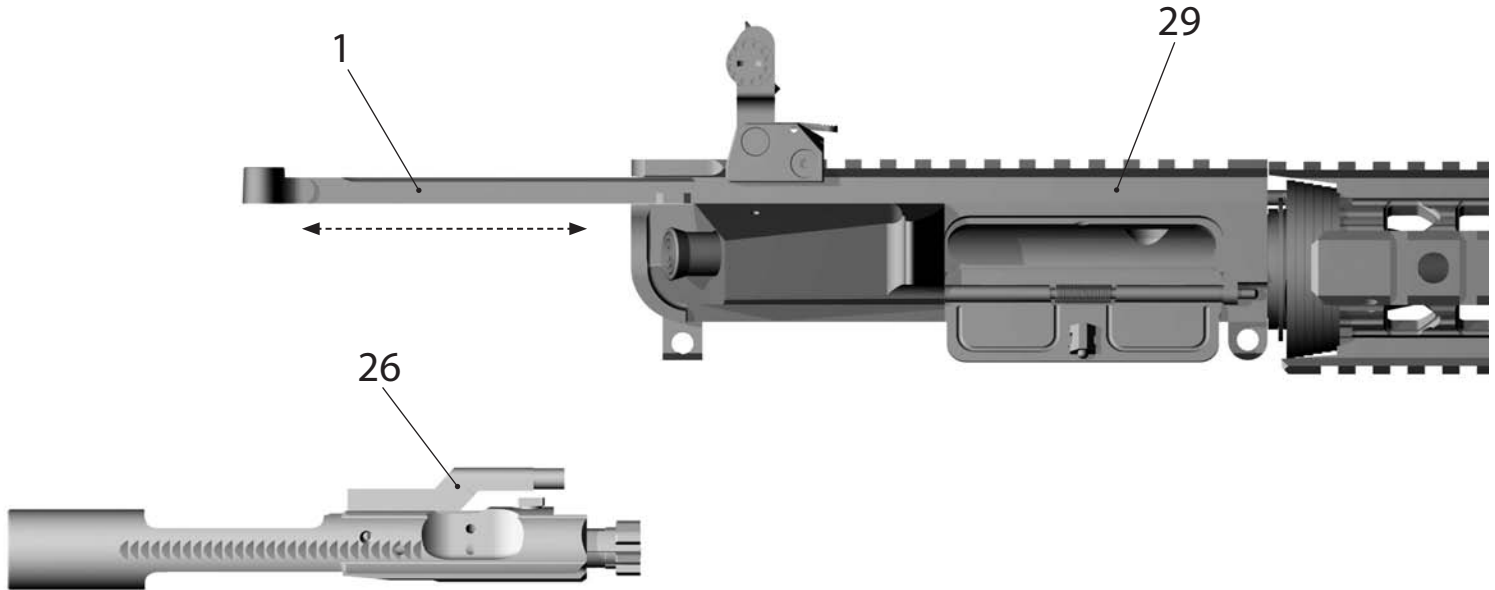

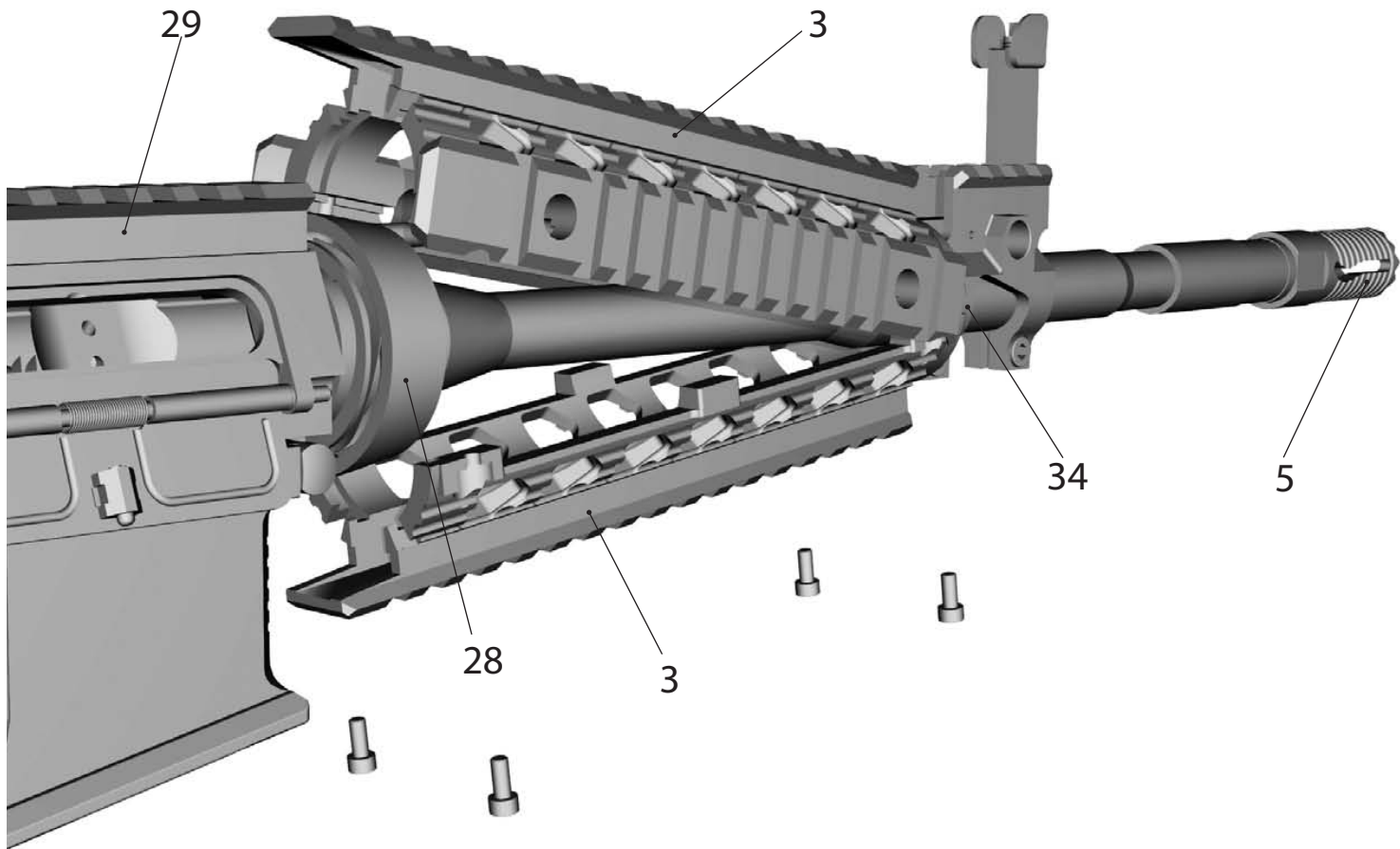

Lower Receiver

- 1 - Push the lever (30) down and slide the buttstock (12) onto the receiver extension (31).
- 2 - Insert the buffer (23) into the action spring (24) and slide them into the lower receiver (32). Push the buffer inward until the buffer retainer (25) snaps up to hold the buffer in place.
- 3 - Assemble the upper receiver (29) to the lower receiver (32) so that the pivot pin holes (27) are aligned. Push the pivot pin (27) in.
- 4 - Push the hammer (22) to rear until locked.
- 5 - Move the selector lever (11) to SAFE.

Important: Failure to move the selector lever (11) to SAFE position before closing receivers may cause the sear to be damaged.

- 1 - Close receivers and press takedown pin (13).

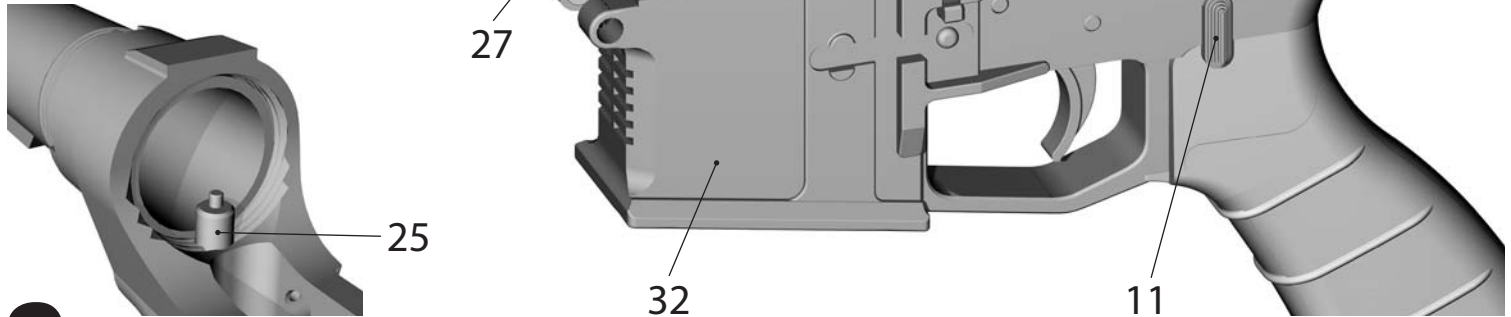

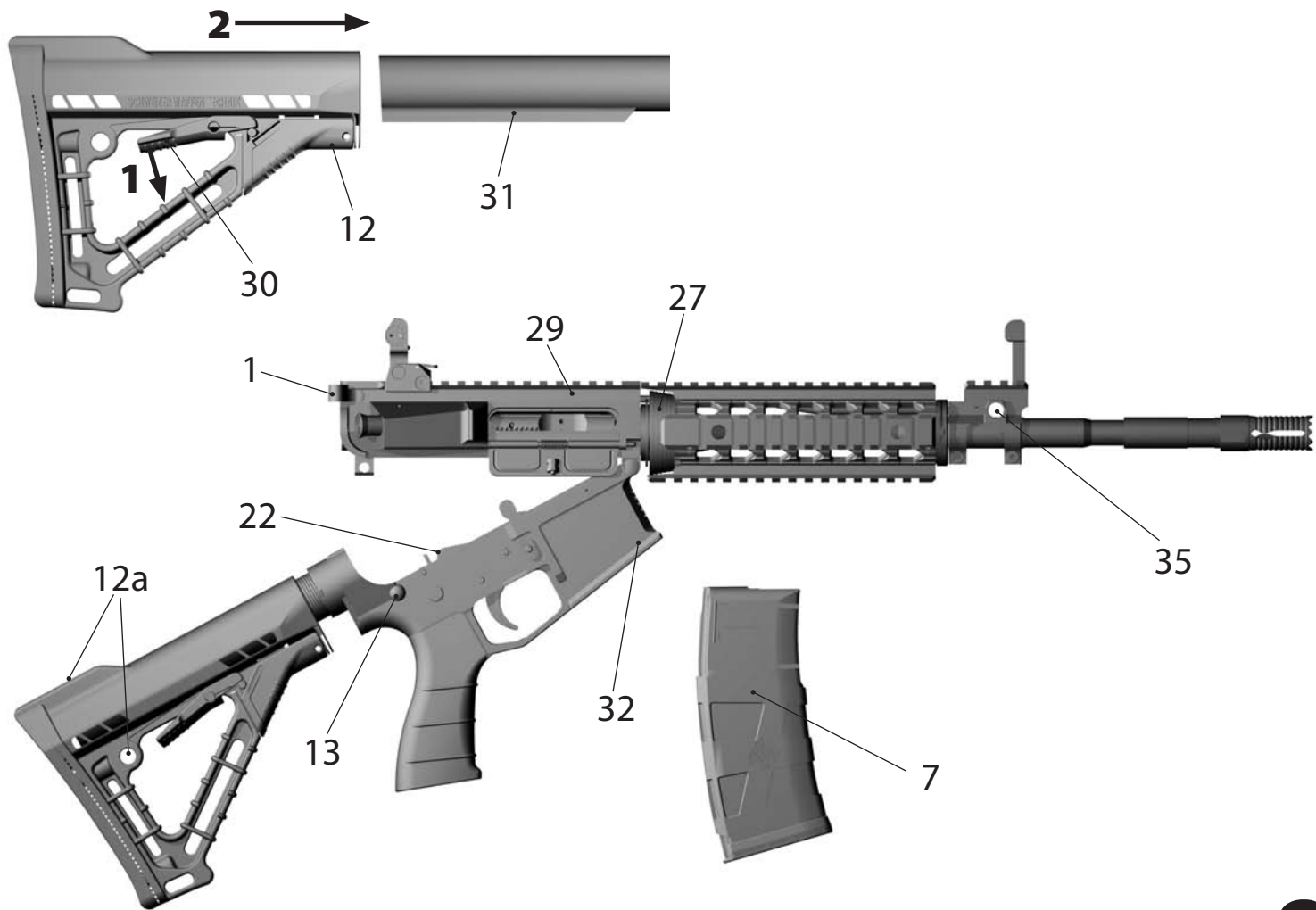

Functional Checks

The functional checks should always be done after cleaning and assembling the weapon. When it fails any functional check, make sure the weapon is clean and assembled properly. If it still fails give it to the unit armorer to repair.

1 - Remove magazine and clear chamber to ensure rifle is not loaded.

Checking Safety

- 1** - Pull charging handle (1) to rear and release it.
- 2** - Set selector (11) on SAFE.
- 3** - Pull trigger (36). You should hear nothing as hammer (22) should not fall. Release trigger.

Checking Semi

- 1** - Set selector lever (11) on SEMI.
- 2** - Pull trigger (36). You should hear a loud click as hammer falls. Keep trigger pulled.
- 3** - Pull charging handle to rear and release it while keeping trigger pulled. Hammer should not fall but be held by the disconnecter (37).
- 4** - Release trigger (36). You should hear a light click as hammer is released from disconnecter and drops part way to engage with trigger sear.

Checking Automatic Action (Auto or Burst)

- 1** - Set selector lever (11) on AUTO or BURST.
- 2** - Pull and keep trigger pulled. You say hear a loud click as hammer falls.
- 3** - Pull charging handle to rear and release it while keeping trigger pulled.
- 4** - Release trigger and listen for a light click as hammer and trigger sear engage. Light click should be heard only on BURST and then only on one out of three.

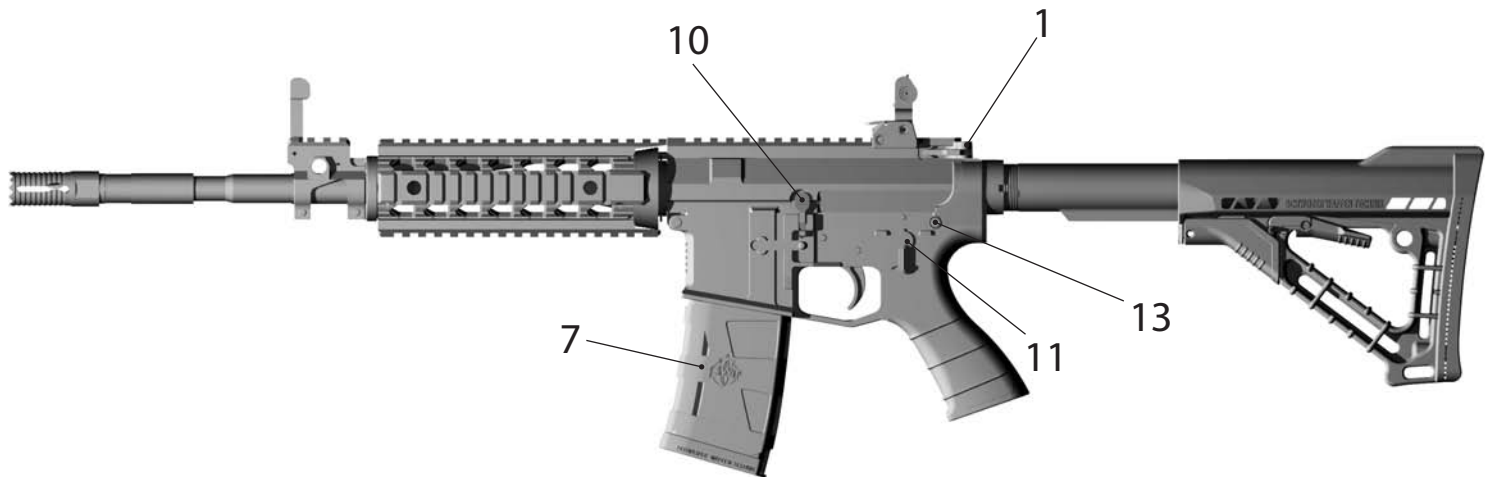

BURST: If there is no click, pull and keep trigger pulled and repeat steps 11 and 12 up to 3 times, until a light click is heard when trigger is released.

AUTO: No click should be heard.

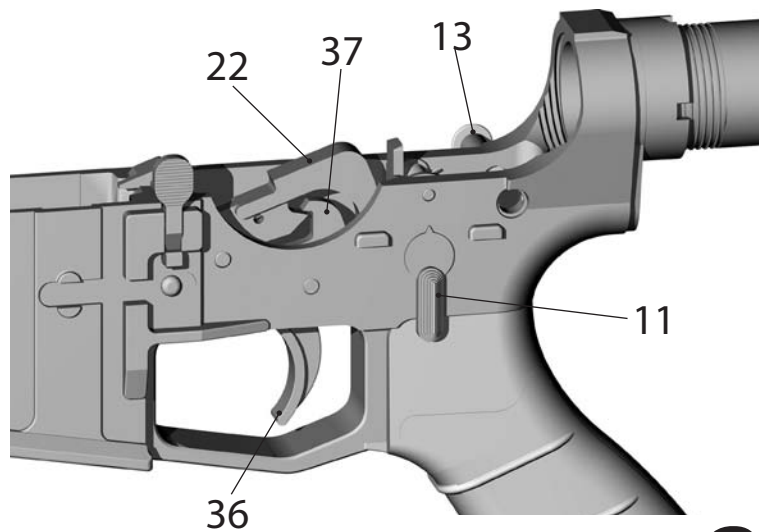

1 - Release trigger and listen for light click as hammer and trigger sear engage. Light click should be heard only on BURST and then only on one out of three.

BURST: If there is no click, pull and keep trigger pulled and repeat steps 11 and 12 up to 3 times, until a light click is heard when trigger is released.

AUTO: No click should be heard.

1- Pull Trigger

BURST: You should hear loud click as hammer falls

AUTO: No click should be heard.

1 - Pull and release charging handle while keeping trigger pulled.

2 - Release trigger. No click should be heard.

3 - Pull trigger. No click should be heard. Keep trigger pulled.

4 - Pull and release charging handle while keeping trigger pulled.

5 - Release trigger. No click should be heard.

6 - Pull trigger. No click should be heard. Keep trigger pulled.

7 - Pull and release charging handle while keeping trigger pulled.

8 - Release trigger.

BURST: You should hear a light click.

AUTO: No click should be heard

1 - Pull trigger.

BURST: You should hear a loud click as hammer falls.

AUTO: No click should be heard.

1 - Release trigger. No click should be heard

Checking Magazine Catch and Bolt Catch

1 - Install an empty magazine (7) and check that it is locked in place by the magazine catch (8).

2 - With empty magazine (7) installed, set fire control lever (11) on SEMI.

3 - Pull charging handle (1) fully back and then push forward into locked position. Bolt carrier assembly should be held to the rear by the bolt catch (10).

4 - Keep fingers clear of the ejection port. Push top of bolt catch (10) to release bolt carrier assembly which will slam forward into the locked position. Release top of bolt catch (10).

5 - Set fire control selector lever (11) on SAFE.

6 - Close ejection port cover (6)

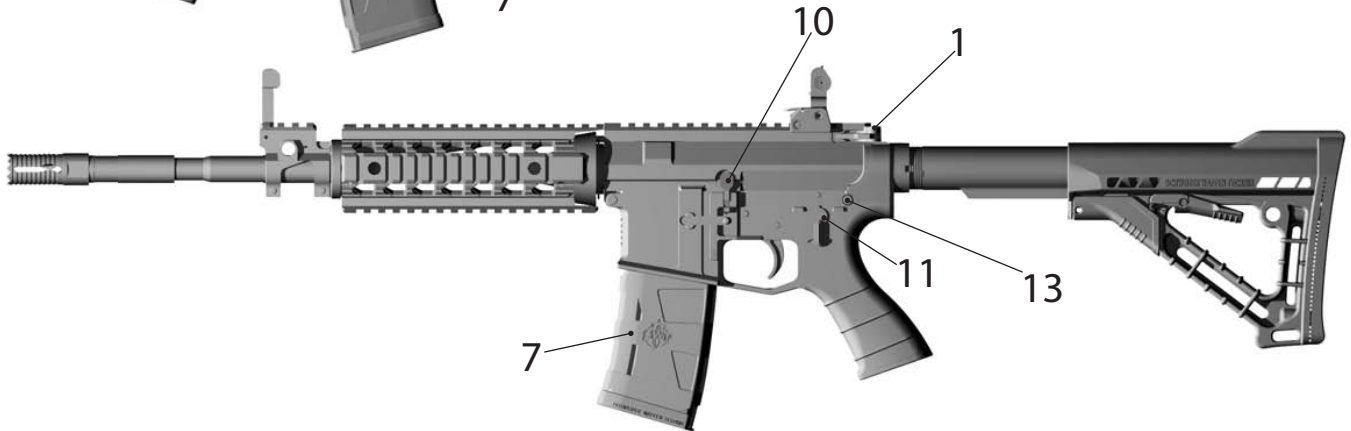
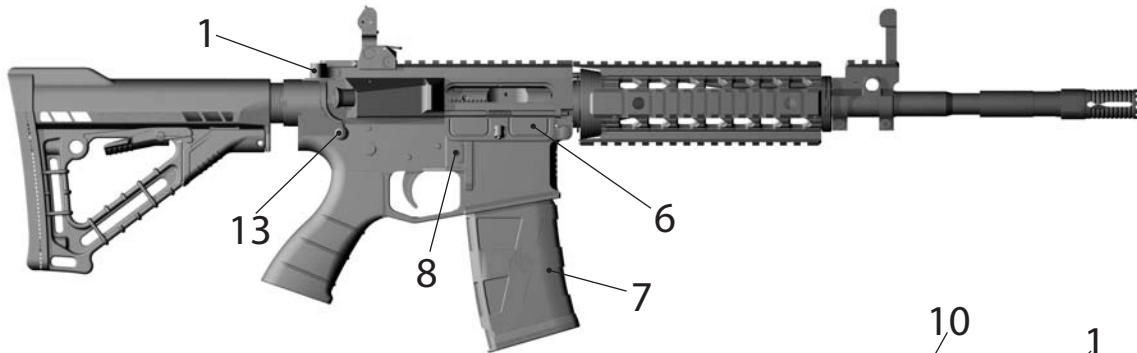

Checking Buttstock

- 1** - Squeeze lever (30) and slide buttstock (12) fully forward. Release lever and check that buttstock locks in position.
- 2** - Squeeze lever (30) and slide buttstock (12) fully rearwards. Release lever and check that buttstock locks in position.

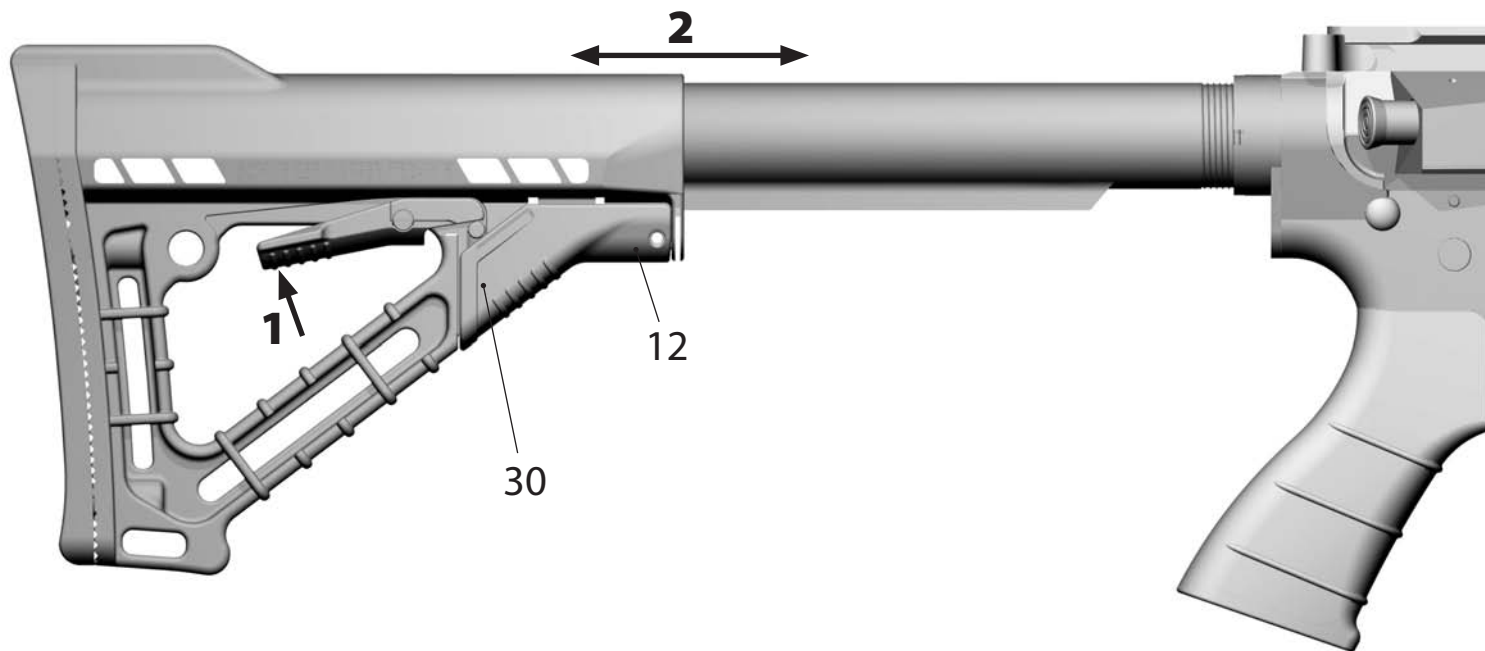

MALFUNCTION AND TROUBLE SHOOTING

MALFUNCTION	PROBABLE CAUSE	CORRECTIVE ACTION
Failure to fire	1. Selector lever on SAFE	Move Selector to SEMI or AUTO or BURST
	2. Damaged firing pin	Replace
	3. Improper assembly of firing pin in bolt carrier group	Remove firing pin and install correctly. Inspect retaining pin for damage
	4. Too much oil in bolt firing pin recess	Disassemble bolt and wipe out excess oil
	5. Fire Control mechanism improperly assembled or with worn, broken or missing parts	Unit armorer repair
	6. Trigger pin improperly installed	Unit armorer remove and install from left side
Failure to unlock (bolt seizes will not rotate from locked position)	1. Bolt group, firing pin, or barrel burred, dirty or carboned-up	Set selector lever to SAFE. Remove magazine. Hold weapon pointing up (stay clear of muzzle) and strike butt sharply and squarely on ground while pulling back on charging handle. Remove bolt group clean and lubricate.

MALFUNCTION	PROBABLE CAUSE	CORRECTIVE ACTION
Failure to Extract	1. Dirty or corroded ammunition	Remove ammunition from magazine and clean both
	2. Carbon and dirt build-up in chamber	Clean chamber
	3. Carbon and dirt build-up in extractor recess or extractor lip	Disassemble and clean
	4. Defective extractor, extractor spring or pin	Replace
	5. Rubber insert not assembled in extractor spring	Unit armorer replacement
	6. Rim shear due to badly pitted chamber	Unit armorer replacement
	7. Separated cartridge case caused by excessive headspace, etc.	Unit armorer repair
Failure to eject	1. Broken ejector	Unit armorer repair
	2. Jammed ejector	Unit armorer repair
	3. Weak or broken ejector	Unit armorer repair
	4. Short recoil	See "Short Recoil" in malfunction column

MALFUNCTION	PROBABLE CAUSE	CORRECTIVE ACTION
Failure to remain cocked	1. Worn, broken or missing parts in fire control mechanism	Unit armorer repair
	2. Hammer pin incorrectly installed	Unit armorer to remove and install correctly
Failure to feed	1. Magazine not seated properly	Magazine catch may not be properly adjusted. Unit armorer adjustment
	2. Dirty or corroded ammunition	Remove ammunition from magazine and clean both
	3. Dirty magazine	Disassemble and clean
	4. Defective magazine	Replace magazine
	5. Too many rounds in magazine	Reload magazine
	6. Restricted buffer action	Remove, clean and lubricate buffer and action spring
	7. Short Recoil	See short recoil in malfunction column
Double feed	Defective magazine	Replace magazine

MALFUNCTION	PROBABLE CAUSE	CORRECTIVE ACTION
Failure to chamber	1. Dirty or corroded ammunition	Remove ammunition from magazine and clean both
	2. Restricted movement of bolt carrier group	Disassemble, thoroughly clean and lubricate the weapon. Remove charging handle from upper receiver, point receiver upward, and install bolt carrier group in receiver. Slowly slide carrier in receiver to check alignment and free movement of carrier key and gas tube. If binding occurs, unit armorer to repair
	3. Bolt cam pin missing	Replace bolt cam pin
	4. Loose or damaged bolt carrier key	Unit armorer repair
	5. Improperly assembled extractor spring	Check with unit armorer for proper installation
	6. Bent gas tube	Unit armorer repair
	7. Carrier key and gas tube misaligned	Unit armorer repair
	8. Damaged ammunition	Replace ammunition
	9. Carbon build-up in chamber	Clean chamber

MALFUNCTION	PROBABLE CAUSE	CORRECTIVE ACTION
Failure to lock	1. Dirt corrosion and carbon build-up on bolt or barrel locking lugs	Clean both
	2. Jammed extractor	Clean and lubricate
	3. Dirt on bolt face	Clean
	4. Jammed ejector	Unit armorer repair
	5. Restricted buffer movement	Remove, clean and lubricate buffer, action spring and inside receiver extension
	6. Damaged ammunition	Replace ammunition
	7. Weak or broken action spring	Replace action spring
Short recoil	1. Gaps in bolt rings not staggered	Stagger bolt rings gaps
	2. Carbon build-up or dirt in carrier key and outside of gas tube	Clean and lubricate bolt carrier group and outside of gas tube
	3. Restricted movement of bolt carrier group or buffer	See "Failure to Lock" in malfunction column
	4. Missing or broken bolt rings or loose carrier key	Unit armorer repair

MALFUNCTION	PROBABLE CAUSE	CORRECTIVE ACTION
Bolt fails to lock to rear after last shot fired	1. Dirty or corroded bolt catch	Clean and lubricate. If further disassembly is necessary, hand to unit armorer to repair
	2. Faulty magazine	Replace magazine
	3. Broken bolt catch or spring	Unit armorer repair
Failure to cycle with selector set at AUTO	1. Worn, broken or missing parts in fire mechanism	Unit armorer repair
Fires with selector set on SAFE	1. Worn, broken or missing parts in fire mechanism	Unit armorer repair
With selector on SEMI, fires when trigger released	1. Worn, broken or missing parts in fire mechanism	Unit armorer repair
Selector lever binds	1. Lack of cleanliness or lubrication	Unit armorer repair
		Unit armorer repair

The following 2 malfunctions apply only to weapons with BURST control.

MALFUNCTION	PROBABLE CAUSE	CORRECTIVE ACTION
Fires fewer than 3-Rounds with selector lever set to BURST	1. Selector lever set to SEMI	Set selector lever to BURST
	2. Normal on first and last burst depending on position of burst control and number of rounds in magazine	Pull trigger immediately to get next full 3-Rounds burst after first burst. Reload and carry on firing after last burst
	3. Trigger released early	Pull trigger (Burst will also be fewer than 3) then pull trigger again for next full 3-Rounds burst
	4. Worm, broken or missing parts in fire mechanism	Unit armorer repair
Fires more than 3 rounds with selector lever set to BURST	1. Worm, broken or missing parts in fire mechanism	Unit armorer repair

Note: Most of the malfunctions already listed could also be caused by damaged faulty or dirty ammunition. Where this is especially likely, a particular note has been included in the list but in other instances time could be saved by making sure that the ammunition is good before investigating the weapon.

OPERATION

Important: Warnings and procedures in this Operation Section must be read and fully understood before operating the weapon.

FIELD SIGHT

Rear Sight (2) Adjustable for windage

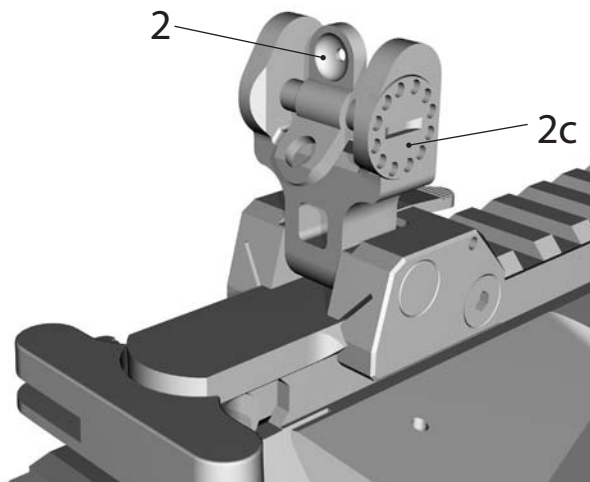

Front Sight (4) Adjustable for elevation

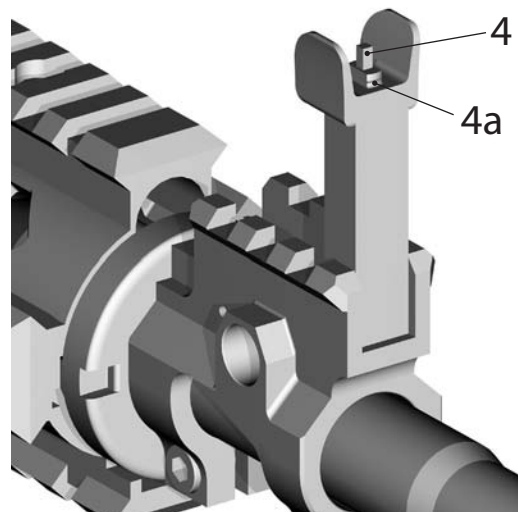

USE OF SIGHTS

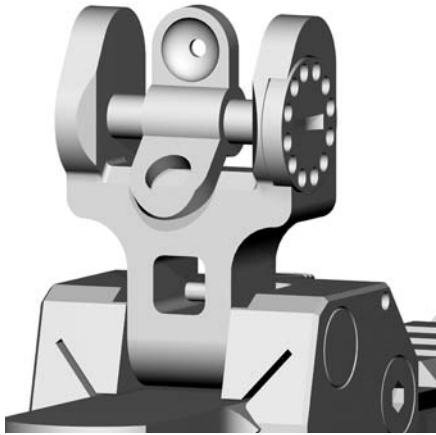

- 1** - Adjust windage on rear sight
- 2** - Adjust elevation on front sight
- 3** - Rear sight has windage drum (2c)
Turn drum clockwise to move point of impact to right.
Turn drum counter-clockwise to move point of impact to left
- 1** - Each click equals .50 MOA of adjustment

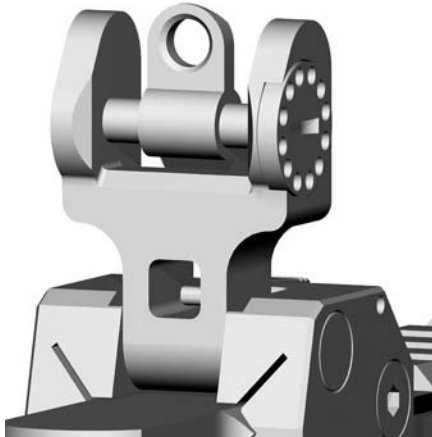

- 1** - Rear sight also has 2-aperture flip-type (Peep) sight for short and long range sighting
- 2** - Aperture, small, in rear sight is for long range (300-500m)
- 3** - Aperture, large, in rear sight is for Short range (0-300m)
- 4** - Front sight post may be turned to adjust for elevation. Turn front sight post clockwise to lower sight and bring point of impact UP
- 5** - Turn front sight post counter-clockwise to raise sight and bring point of impact DOWN

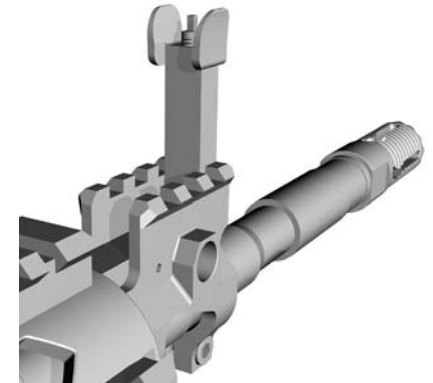
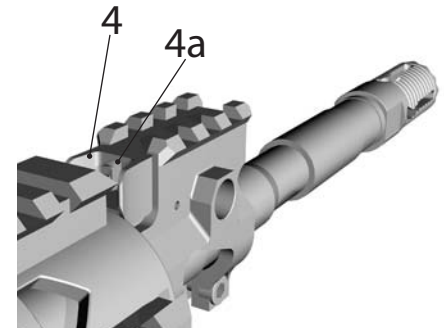

LOADING

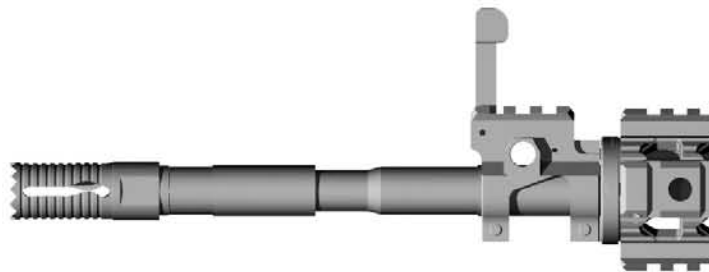

- 1** - Place round (38) in magazine (7) and press down
- 2** - Repeat step 1 until magazine is loaded with required number of rounds, 30
- 3** - Pull charging handle (1) to rear. Push in lower portion of bolt catch (10). Push charging handle forward to latched position
- 4** - Set fire control selector (11) on SAFE
- 5** - Insert magazine (7) into magazine housing (32a) and ensure magazine catch is engaged
- 6** - Press upper portion of bolt catch (10) to release bolt and chamber round
- 7** - Weapon is now loaded

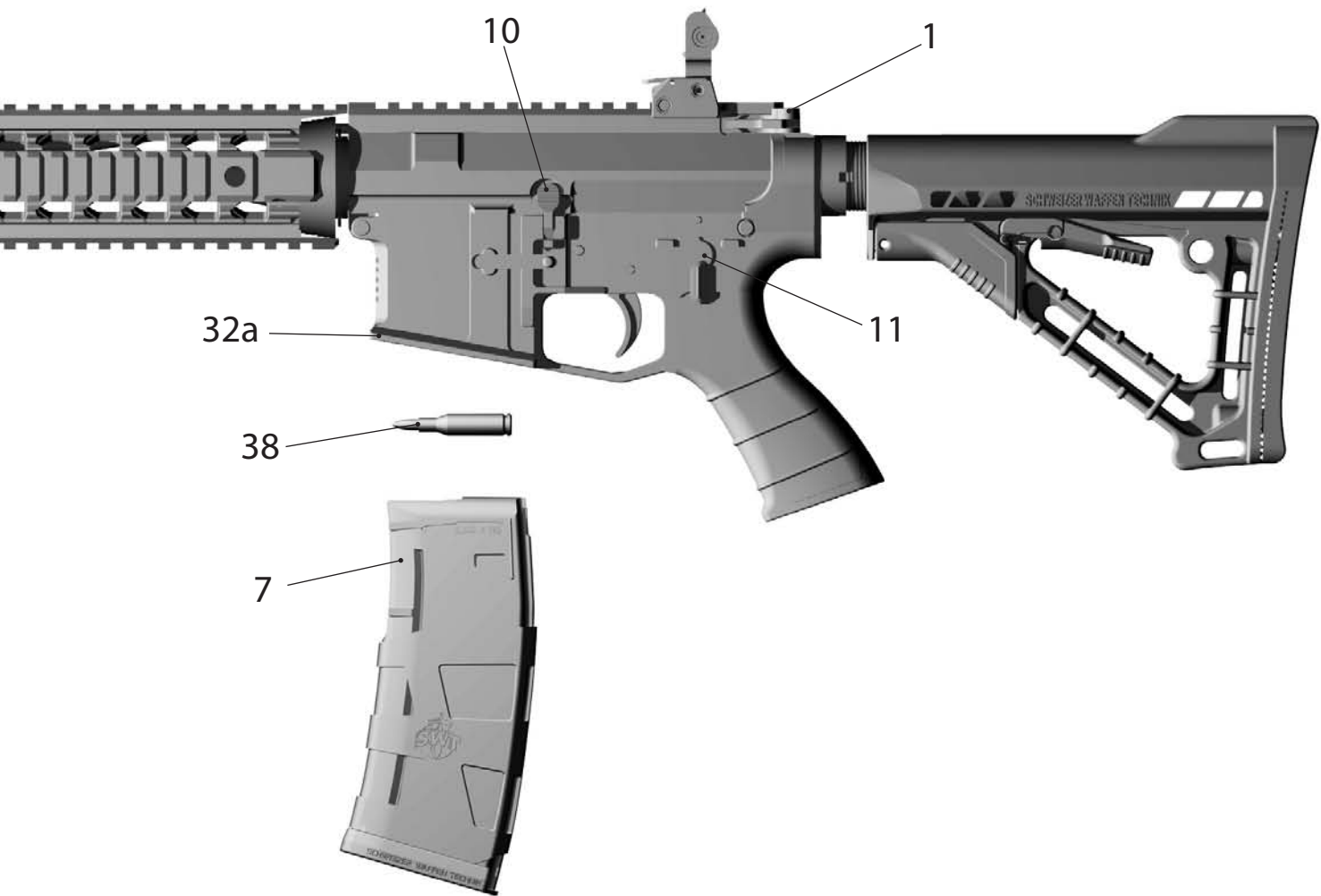

AIMING AND FIRING

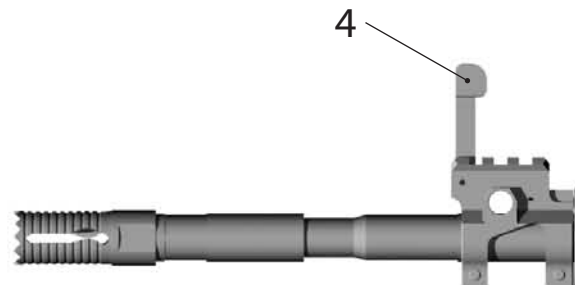

Caution: *Keep weapon pointed in in safe direction and load a round into the chamber.*

- 1** - Pull charging handle (1) to rear. Push in lower portion of bolt catch (10). Push charging handle forward to latched position
- 2** - Set fire control selector on SAFE
- 3** - Insert loaded magazine and push upper portion of bolt catch to release bolt and chamber round
- 4** - Assess range to target and set sight
- 5** - Set fire control selector (11) on SEMI or AUTO (or BURST)
- 6** - Hold weapon with both hands; one hand on handguard, the other on pistol grip
- 7** - Align the target with top of front sight (4) and center of rear peep sight aperture
- 8** - Pull trigger (36) to fire 1 round SEMI or any number of rounds on AUTO up to magazine capacity

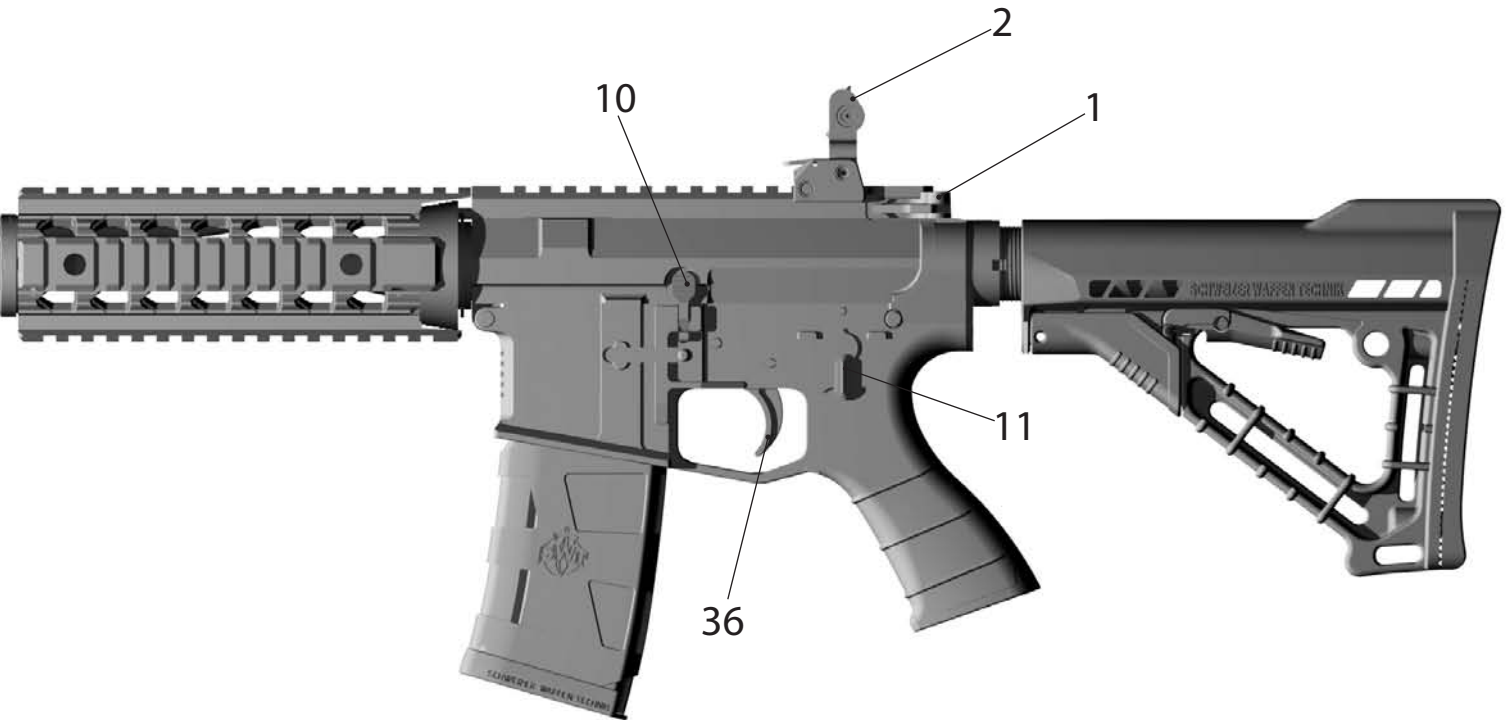

9 - If your weapon has a BURST fire control when BURST is selected, the first and last burst may be 1, 2 or 3 rounds depending on position of burst control mechanism and number of rounds in magazine. Between first and last, all burst are limited to 3 rounds. Trigger (36) must be released and squeezed again to fire next burst of 3 rounds

10 - Release trigger and set fire control selector on SAFE

UNLOADING

- 1 - Set fire control selector (11) on SAFE and keep weapon pointing in a safe direction
- 2 - Press magazine catch (8) and remove magazine (7)
- 3 - Pull charging handle (1) to rear. Check that cartridge is ejected from chamber (15)

Note: If cartridge is not ejected, ensure barrel is cool to avoid risk from cook-offs

- 1- While holding charging handle to rear, push in lower portion of bolt catch (10). Push charging handle forward to latched position

CAUTION: Weapon is clear only when chamber (15) is empty, magazine (7) removed, bolt carrier is to rear and fire control selector is on SAFE

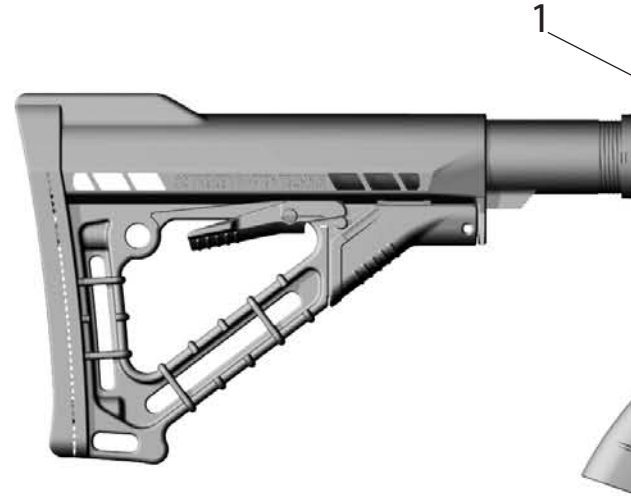

UNLOADING – Cartridge Not Ejected

- 1 - Pull charging handle (1) to rear. While holding charging handle to rear, push in lower portion of bolt catch (10). Push charging handle forward to latched position
- 2 - Insert the cleaning rod through the flash suppressor (5) to the chamber (15) and push cartridge out
- 3 - Cartridge should not be used again because it may be damaged.

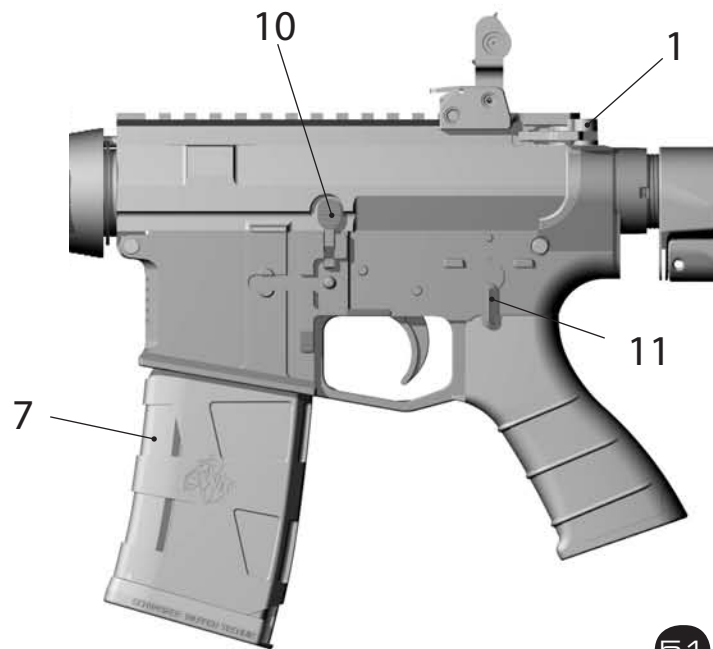
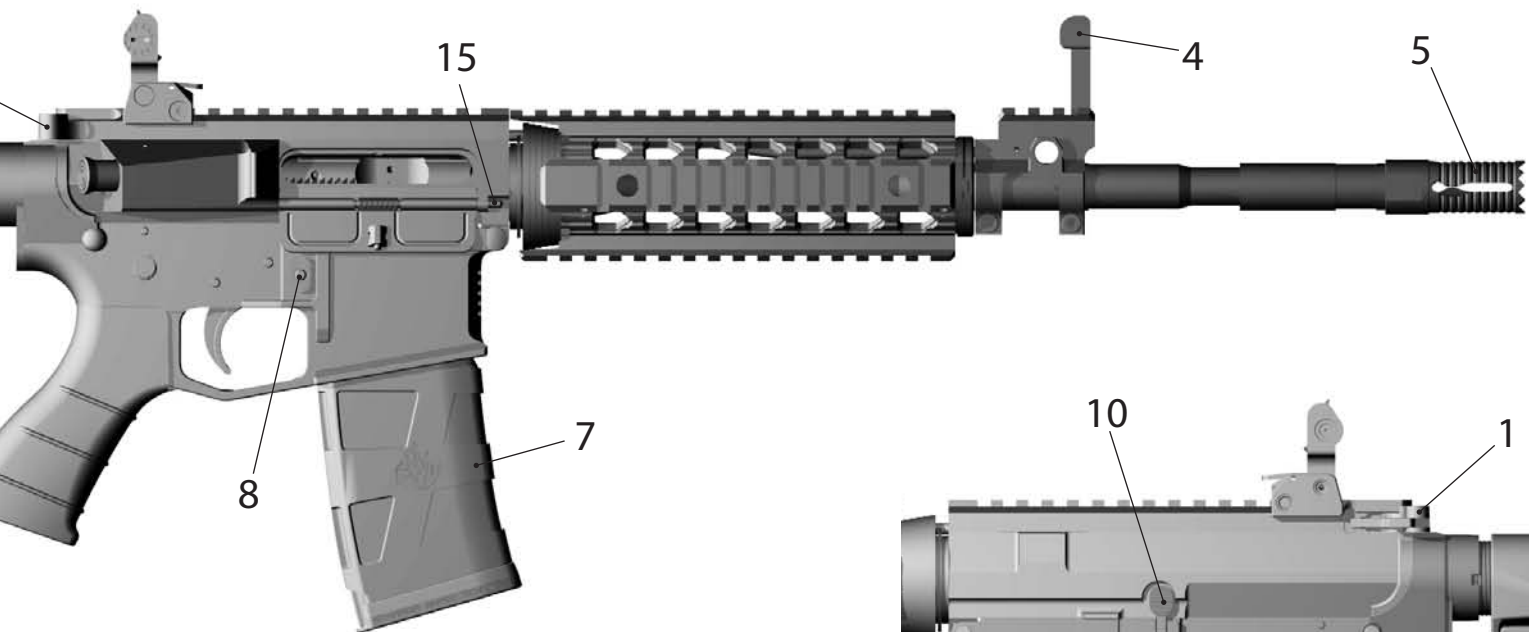

STOPPAGE AND IMMEDIATE ACTIONS

Stoppage: A stoppage is any unintentional interruption of firing

Immediate Action: Immediate action is the action taken as rapidly possible to correct a stoppage without analyzing the cause. Immediate action is as follows

- 1** - Tap upward on the bottom of the magazine to be sure it is locked in position. Pull charging handle fully and sharply to the rear watch for ejection of a fired or unfired round
- 2** - If a cartridge or case is ejected, release the charging handle sharply to chamber a new round (do not “hang on” to the charging handle as it goes forward)
- 3** - Strike forward assist to ensure bolt closure
- 4** - Attempt to fire. If weapon fails to fire, inspect to determine the cause of the malfunction and take appropriate action
- 5** - If a cartridge or case is not ejected, check to see if there is a round in the chamber. If the chamber is clear, release the charging handle to feed a new round and attempt to fire. If the weapon still fails to fire, refer to the “Malfunction Section”
- 6** - If a cartridge or case is seen in the chamber, and the barrel is cool or just warm, the cartridge or case should be removed, refer to the “Unloading Section”

DANGEROUS SITUATIONS

Misfire and Cook-Offs

Although misfires are rarely encountered with properly maintained weapons and clean ammunition, misfires and cook-offs are potentially dangerous, particularly if a heavy firing schedule is being followed. It is important that proper corrective action be taken

Misfire

A misfire is a failure to fire when the hammer falls due to mechanism malfunction or faulty cartridge. The cartridge should be ejected immediately.

COOK-OFF

A cook-off is an accidental firing of a chambered round caused by the cartridge absorbing excess heat from a very hot barrel. The live cartridge may have failed to eject when clearing the weapon, or it may have been fed into the chamber ready for the next shot, it may also remain in the chamber if it misfired or failed to fire.

Whatever the reason, when a live round remains in the chamber when the barrel is very hot there is a risk of accidental discharge.

Warning: A Cook-Off can occur any time after chambering a round in a very hot barrel, so keep the weapon pointing in a safe direction.

Immediate Action: To prevent damage or injury from cook-off when the barrel is very hot complete the followings actions immediately

- 1** - Remove Magazine
- 2** - Pull charging handle fully rearward. If chamber is empty, lock action open by pressing in bottom of bolt catch. If round remain in chamber, skip step 3 and see step 4.
- 3** - Allow barrel to cool for 15 minutes.
- 4** - If round remains in chamber, release charging handle, allow bolt to move forward
- 5** - Fire round if safe to do so, if not safe, see step 6.
- 6** - If not safe to fire lay weapon on the ground pointing in a safe direction with ejection port toward the ground, and step back.
- 7** - Stand clear and keep others clear, and wait 15 minutes for barrel to cool.

WARNING: Cook-Off could occur during this cooling period

- 1** - After barrel is cool, remove round from chamber, then have weapon checked by the unit armorer before firing again.

WATER IN THE BARREL

WARNING: *do not attempt to fire if water is in the barrel from fording, heavy rain, or heavy fog. Snow, mud, sand and any other obstruction must be removed from the barrel bore before firing. If you attempt to fire with any kind of obstruction in the barrel it may bulge or burst.*

1 - To remove water from the barrel, hold the rifle muzzle down, pull the charging handle to the rear about 1.2cm to vent the barrel and at the same time shake the weapon vigorously.

2 - Release charging handle.

3 - The weapon can now be fired.

Note: *Clean and lubricate the weapon as soon as possible after clearing any obstruction, or whenever it has been wet.*

BULLET IN BARREL

CAUTION: *If a noticeable difference in sound or recoil is experienced, stop firing. A bullet could be stuck in the barrel. If a bullet is stuck in the barrel, give weapon to unit armorer to dislodge the bullet.*

EXPLODED VIEW & PARTS LIST

LOWER RECEIVER

- LR1 Lower Receiver
- LR2 Bolt Catch
- LR3 Bolt Catch Pin
- LR4 Bolt Catch Plunger
- LR5 Bolt Catch Spring
- LR6 Buffer Retainer
- LR7 Buffer Retainer Spring
- LR8 Selector Spring
- LR9 Fire Control Selector Detent
- LR10 Fire Control Selector
- LR11 Magazine Catch
- LR12 Magazine Release Button
- LR13 Magazine Release Button Spring
- LR14 Take Down Pin
- LR15 Take Down Pin Spring
- LR16 Take Down Pin Detent
- LR17 Grip
- LR18 Grip Lock Washer
- LR19 Grip Screw
- LR20 Pivot Pin

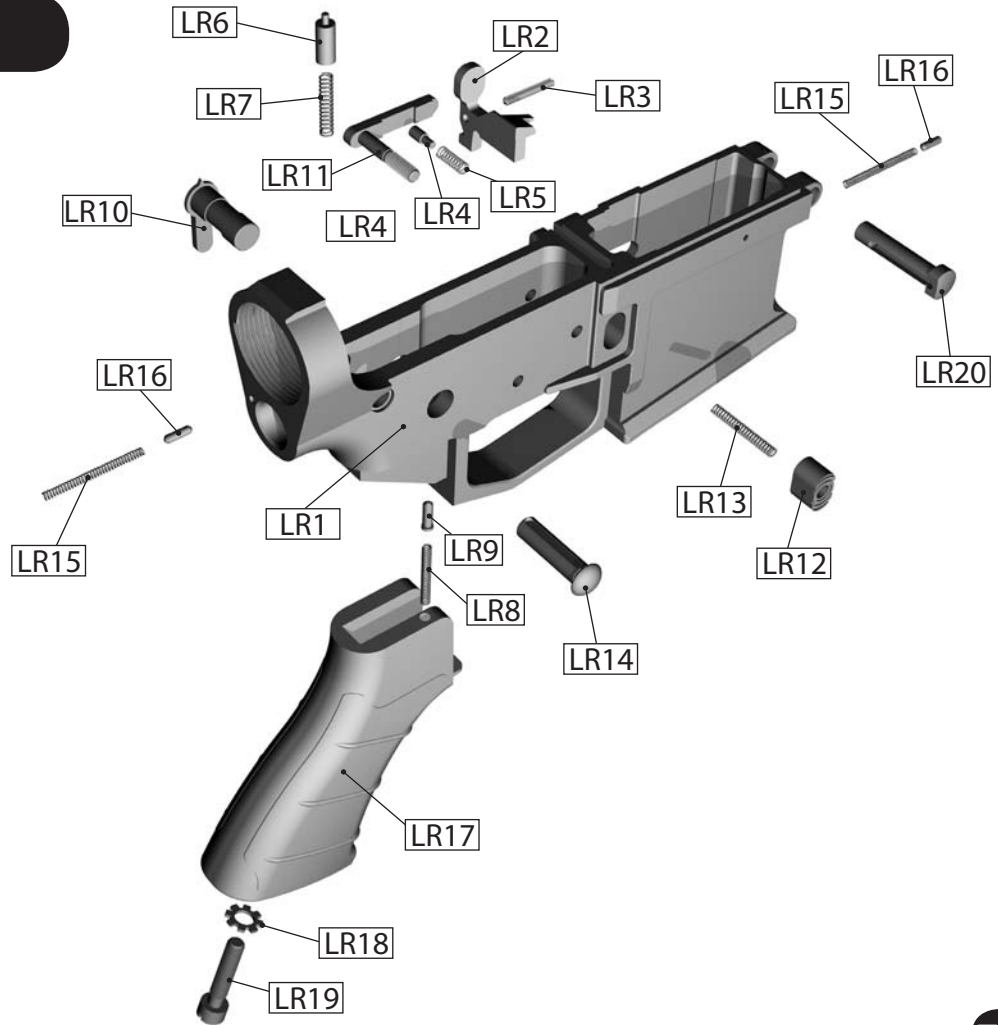

BARREL & GAS TUBE

- GT1 Barrel
- GT2 Gas Tube Assembly
- GT3 Gas Tube Pin
- GT4 Gas Block
- GT5 Flash Suppressor
- GT6 Washer
- GT7 Sight Post

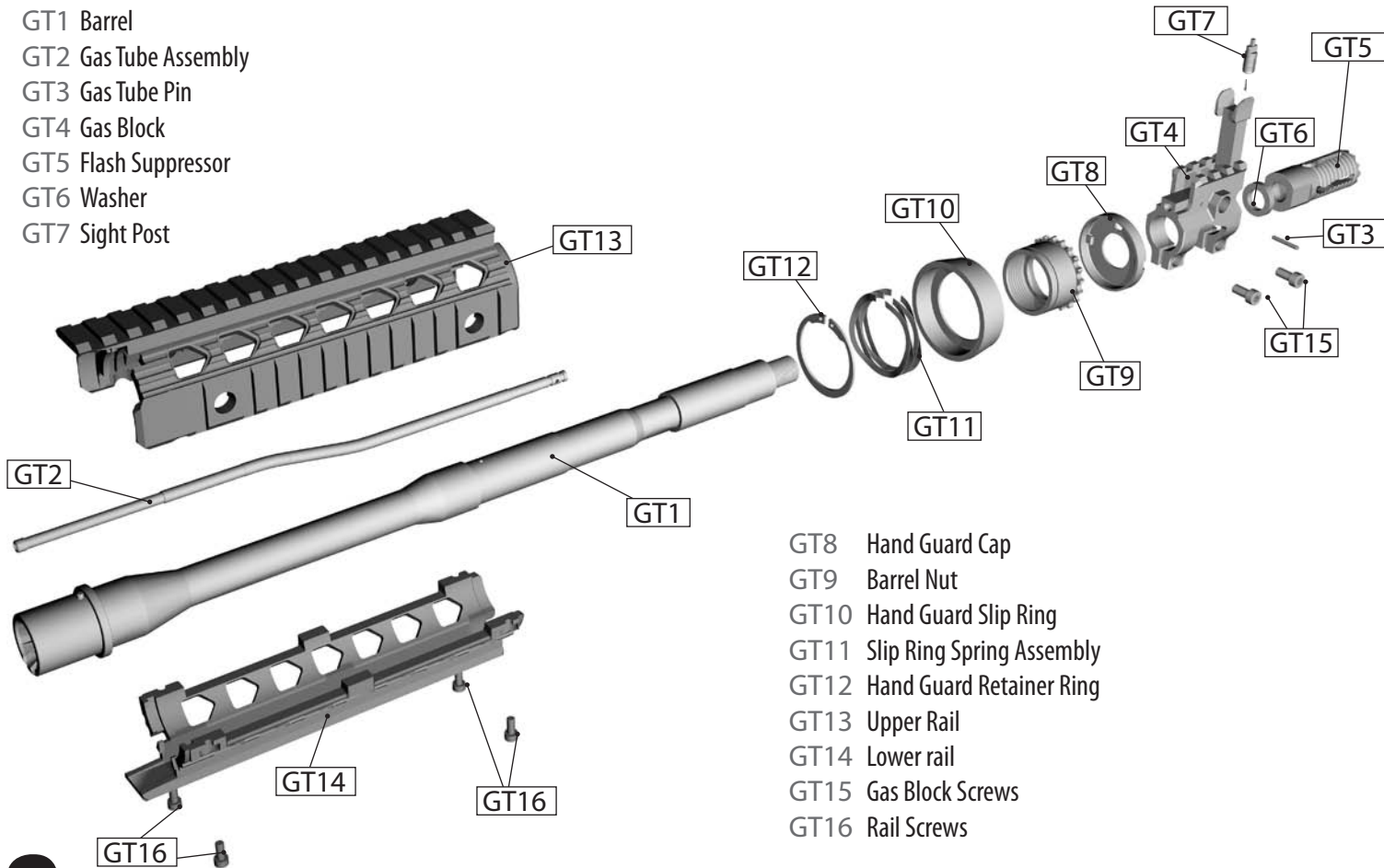

- GT8 Hand Guard Cap
- GT9 Barrel Nut
- GT10 Hand Guard Slip Ring
- GT11 Slip Ring Spring Assembly
- GT12 Hand Guard Retainer Ring
- GT13 Upper Rail
- GT14 Lower rail
- GT15 Gas Block Screws
- GT16 Rail Screws

FIRE CONTROL FULL AUTO

- FC1 Disconnecter
- FC2 Disconnecter Spring
- FC3 Hammer
- FC4 Hammer & Trigger Pin
- FC5 Hammer Spring
- FC6 Trigger
- FC7 Trigger Spring
- FC8 Sear
- FC9 Sear Spring
- FC10 Sear Pin

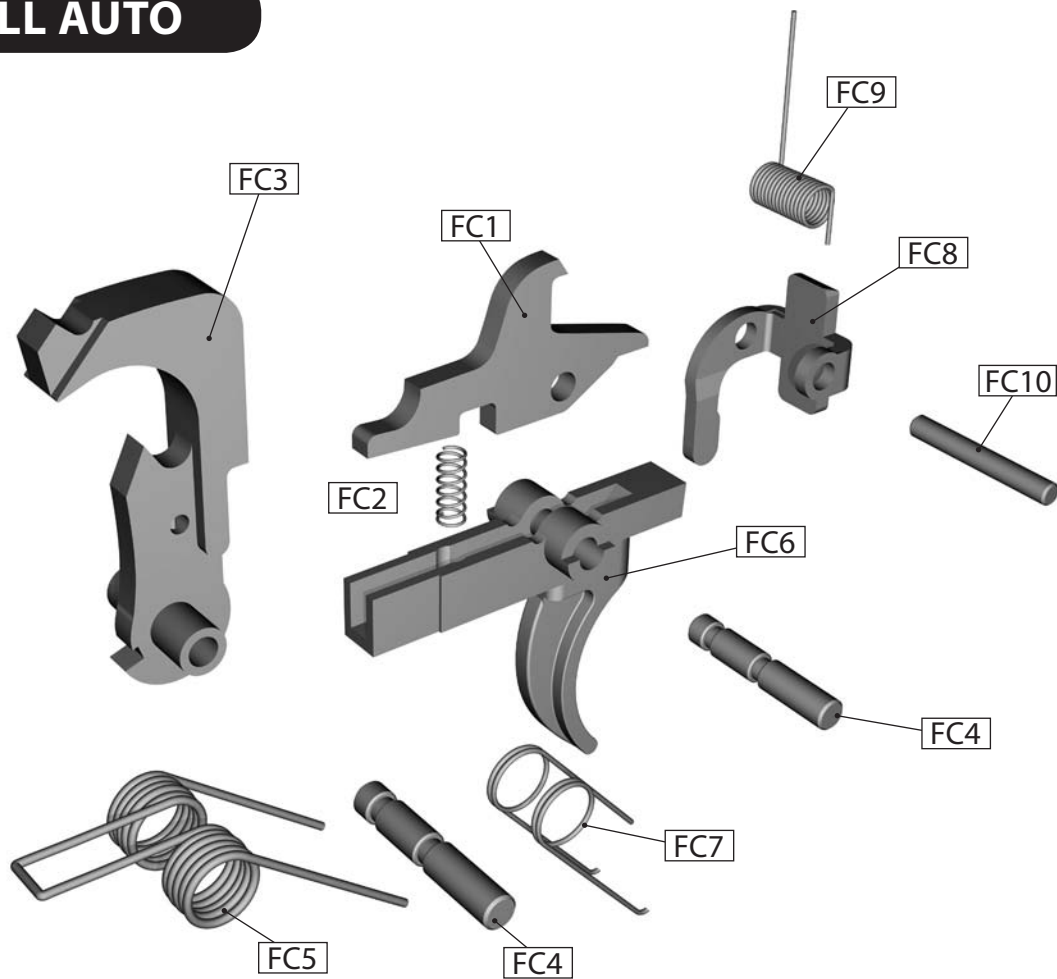

FIRE CONTROL BURST

- FC1L Disconnecter LH
- FC1R Disconnecter RH
- FC2 Disconnecter Spring
- FC3 Hammer
- FC4 Hammer & Trigger Pin
- FC5 Hammer Spring
- FC6 Trigger
- FC7 Trigger Spring
- FC8 Sear
- FC9 Sear Spring
- FC10 Sear Pin
- FC11 Cam
- FC12 Cam Spring

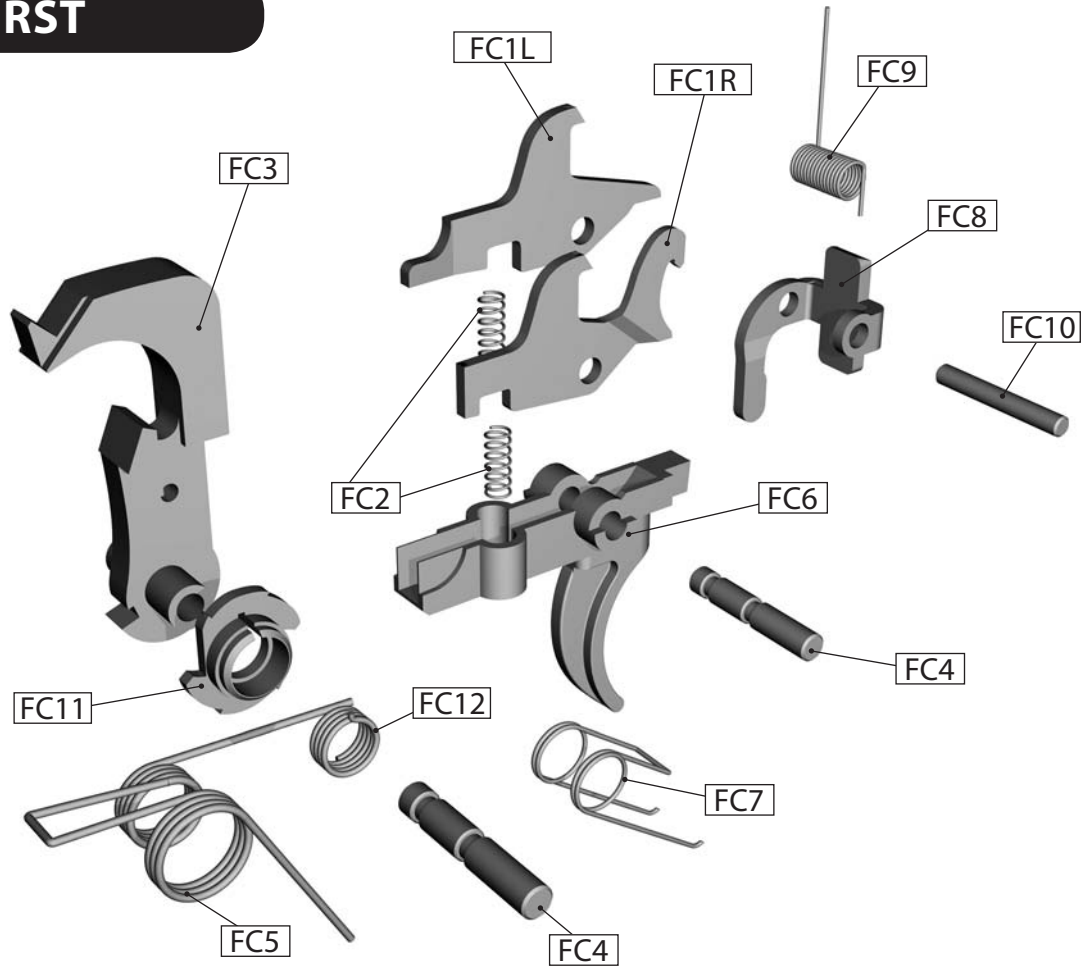

FIRE CONTROL SEMI

- FC1 Disconnecter
- FC2 Disconnecter Spring
- FC3 Hammer
- FC4 Hammer & Trigger Pin
- FC5 Hammer Spring
- FC6 Trigger
- FC7 Trigger Spring

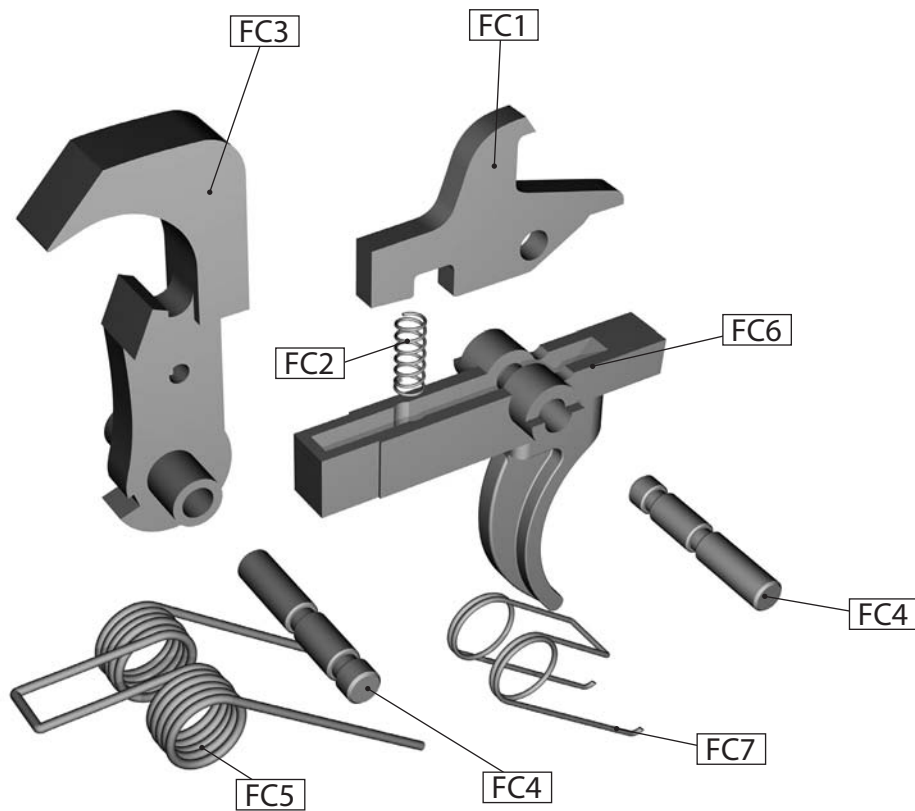

BOLT CARRIER

- BC1 Bolt Carrier
- BC2 Firing Pin
- BC3 Firing Pin Retaining Pin
- BC4 Bolt Carrier key
- BC5 Cam Pin
- BC6 Socket Head Screw
- BC7 Bolt
- BC8 Extractor Pin
- BC9 Ejector & Plunger Retainer Pin
- BC10 Bolt Ring (3)
- BC11 Extractor
- BC12 Extractor Spring Assembly
- BC13 Ejector Spring
- BC14 Ejector

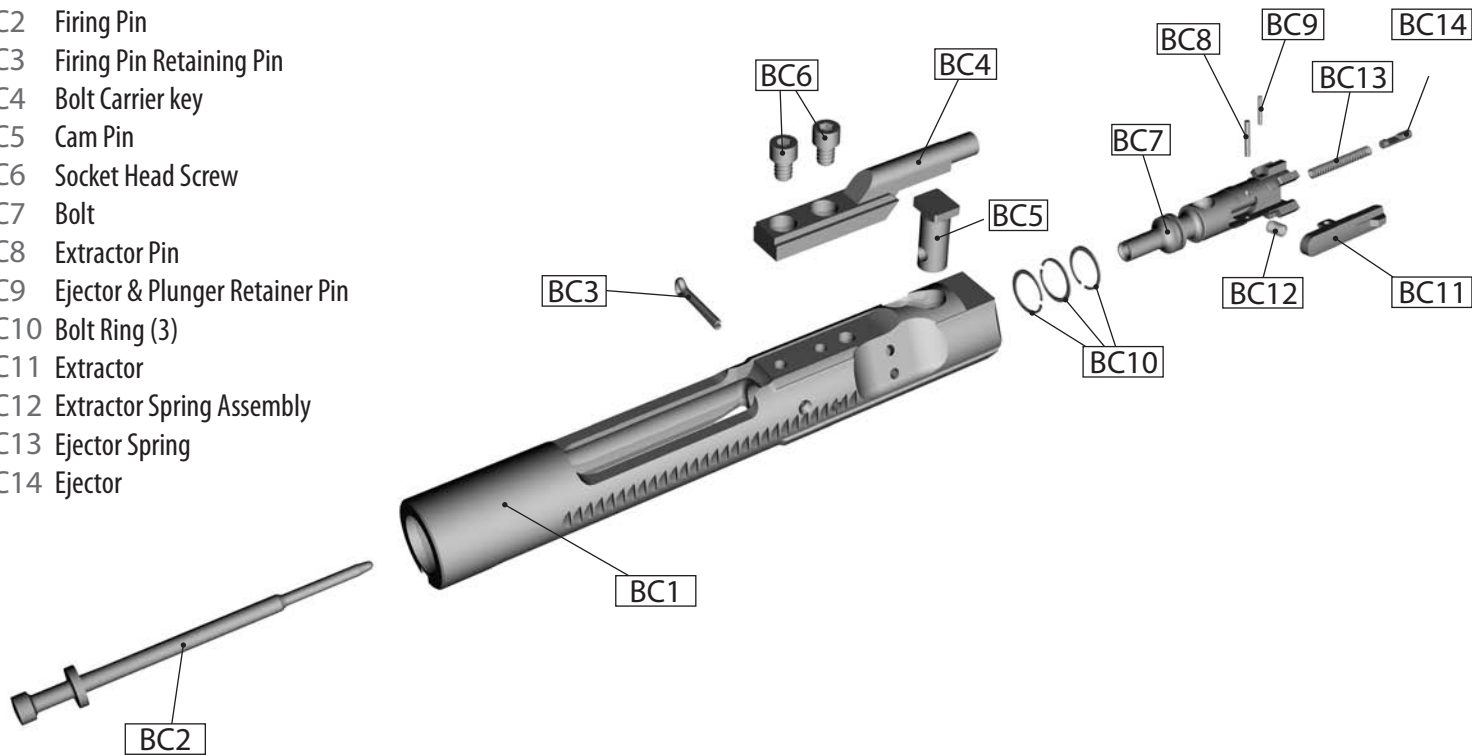

UPPER RECEIVER

UR1 Upper Receiver

UR2 Charging Handle Assembly

UR3 Forward Assist assembly

UR4 Forward Assist Spring

UR5 Forward Assist Retainer Pin

UR6 Ejection Port Cover Assembly

UR7 Ejection Cover Spring

UR8 Ejection Cover Hinge Pin Assembly

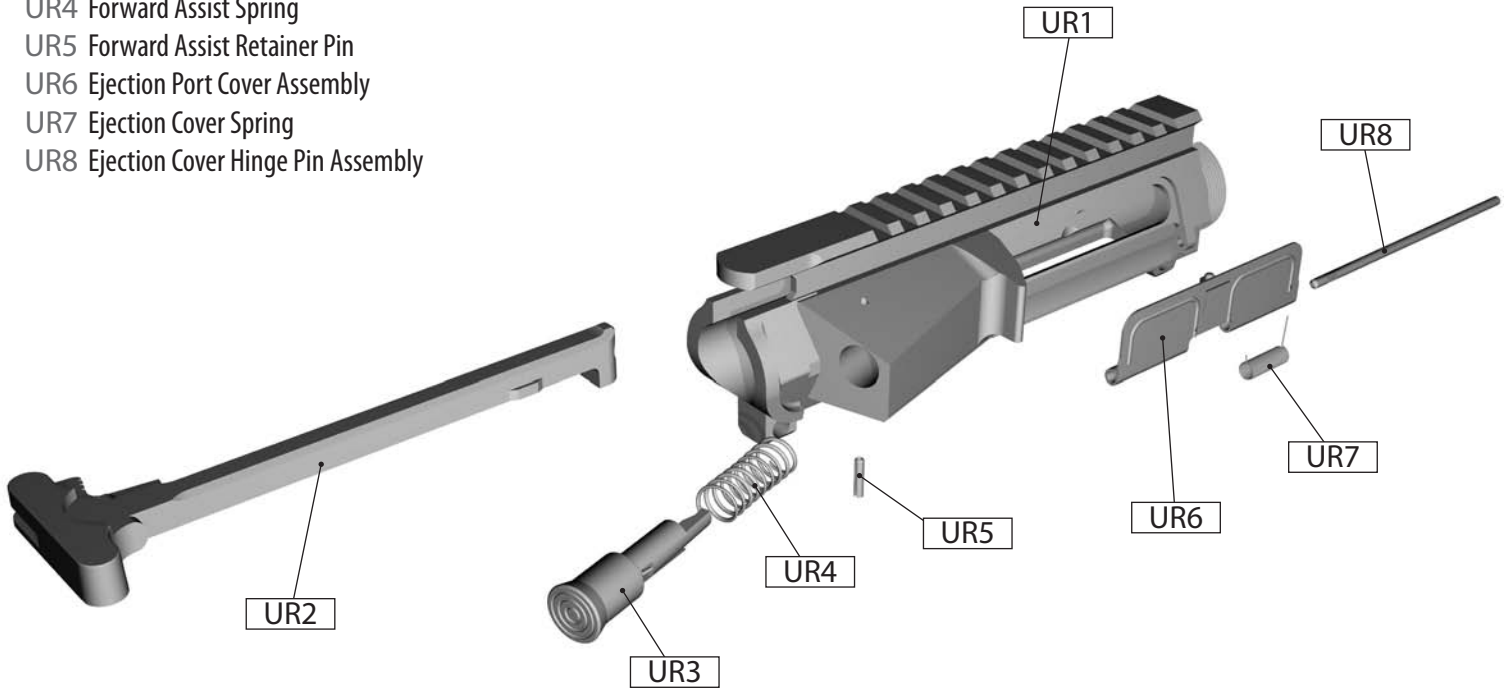

COLLAPSIBLE STOCK

- CS1 Collapsible Butt Stock
- CS2 Receiver Extension (Collapsible)
- CS3 Receiver Extension Nut
- CS4 Receiver End Plate
- CS5 Buffer Assembly
- CS6 Action Spring

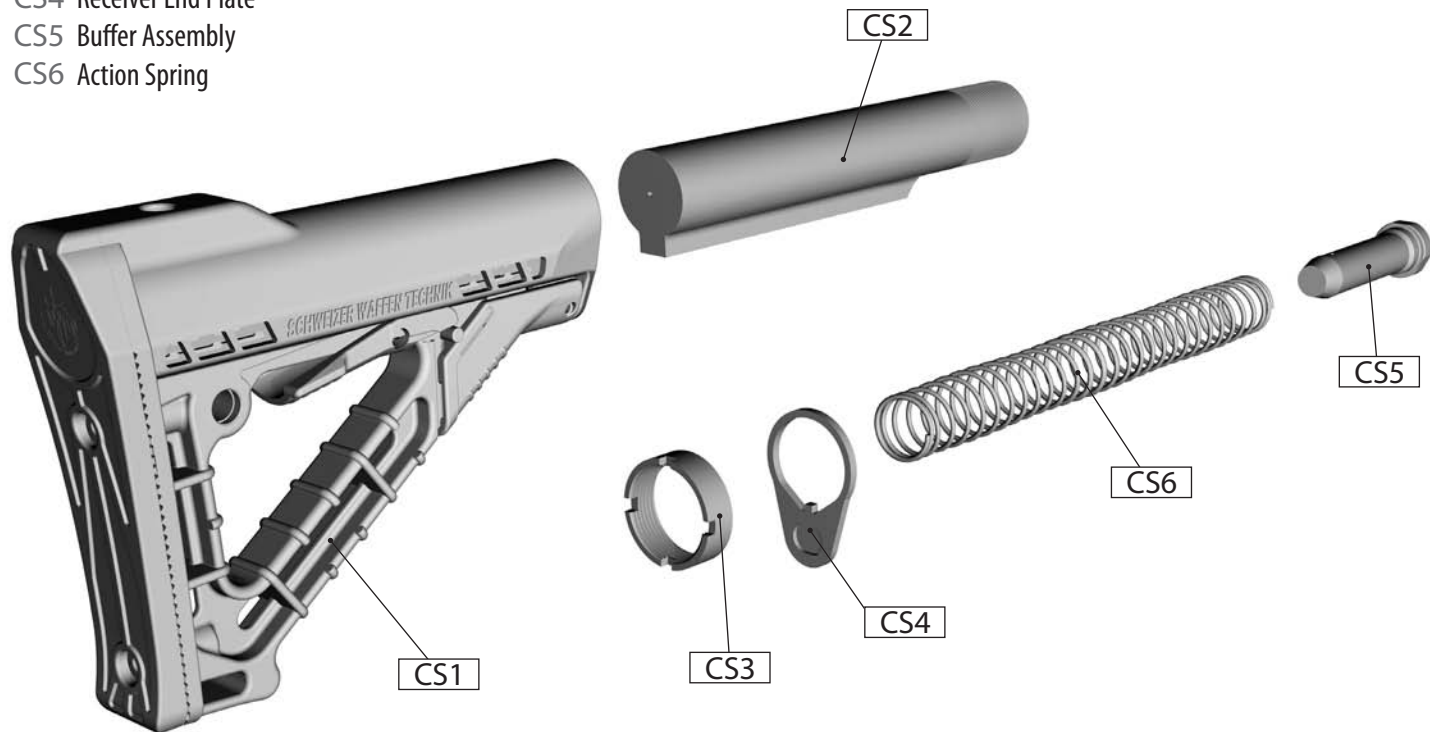

WARRANTY

LIFETIME LIMITED WARRANTY ASTRA SA, warrants to the initial end user purchaser that the product it sells will be free of defects in workmanship or material during his or her lifetime as long as he or she owns the product. If any failure to conform to this warranty becomes apparent during this period, ASTRA shall upon prompt, written notice and compliance by the customer with such instructions as it shall give with respect to the return of defective products or parts, correct such non-conformity by repair or replacement, F.O.B. factory, of the defective part or parts. Correction in the manner provided above shall constitute a fulfillment of all liabilities of ASTRA with respect to the quality of the products. This warranty shall not cover any damage or condition determined by ASTRA to be caused by carelessness, negligence, misuse, normal wear and tear, or failure to properly maintain the products or unauthorized repairs or modifications. The foregoing warranty is exclusive and in lieu of all other warranties of quality, whether written, oral or implied (including any warranty of merchantability or fitness for purpose).

DISCLAIMER OF LIABILITY ASTRA SA, assumes no responsibility for damage and/or injury caused in whole or in part by handloaded, reloaded, remanufactured, or defective ammunition. Under no circumstances shall ASTRA SA be held responsible for incidental or consequential damages with respect to economic loss or injury to property arising out of negligent use of handloaded or remanufactured ammunition, unsafe handling or unauthorized modifications to the firearm. ASTRA SA, will not be responsible for the results of careless handling, unauthorized repairs and adjustments, corrosion, neglect, or unreasonable use (ordinary wear and tear excepted).

EXCLUSION This Limited Lifetime Warranty does not cover the Tritium Night Sights that might be installed on some models. If the sights are not marked ASTRA SA, please reference to the manufacturer indicated on the sight. In any case NEVER DISASSEMBLE a sight containing Tritium. Only the sight's manufacturer is allowed to disassemble it according to the license he holds, issued by the Nuclear Regulatory Commission.



ASTRA S.A.
C. P. 103
1950 Sion
Switzerland
Phone +41 27 322 37 06
Fax +41 27 322 37 07

astra@astra-arms.ch
www.astra-arms.ch