



SEMI-AUTOMATIC PISTOL

MODEL 30 PK

LIGHT ALLOY FRAME

DOUBLE ACTION

cal. 9 mm. parabellum

STAR BONIFACIO ECHEVERRIA S. A.

EIBAR (Spain)

“STAR”
SEMI-AUTOMATIC PISTOL
MODEL 30 PK DOUBLE ACTION

CALIBRE 9 mm PARABELLUM





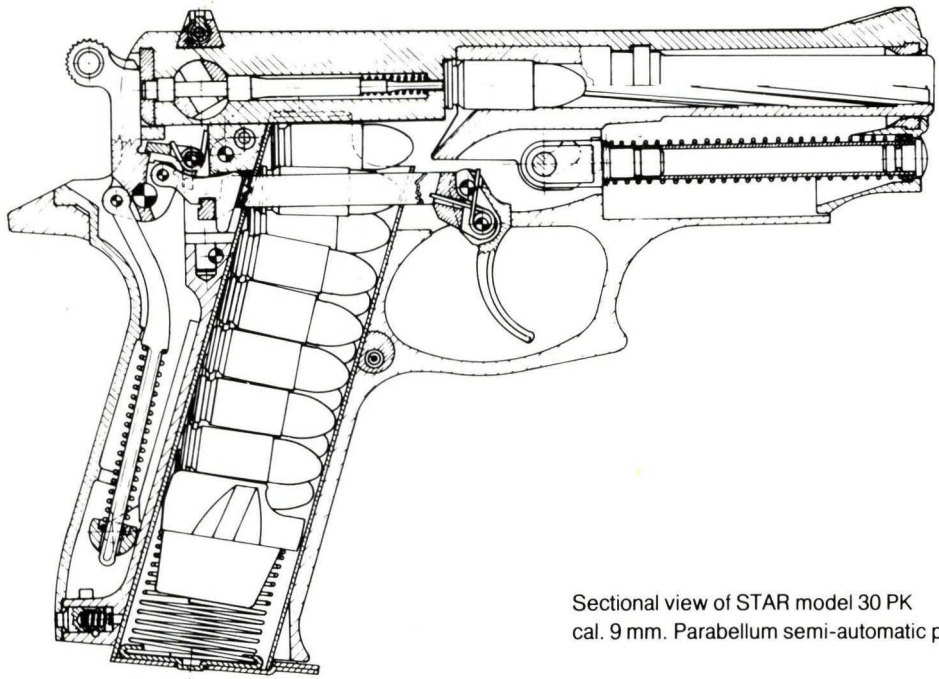

Sectional view of STAR model 30 PK
cal. 9 mm. Parabellum semi-automatic pistol.

GENERAL DESCRIPTION

FUNCTIONING:

- Operating principle Semi-automatic with short recoil of barrel.
- Locking system Rib on top of barrel engaging recess in ceiling of slide when breech-block face of slide strikes barrel on its forward movement and pushes it ahead and up on its oval shaped pivoting hole in barrel lugs.
- Firing mechanism Double action.

SAFETIES:

- a) Manual ambidextrous safety When in ON position, the firing pin is forced in to prevent the hammer from striking it when rocking forward.
- b) Automatic safeties Magazine safety disengaging trigger bar from sear when magazine is removed.
- Half-cock safety notch on hammer to prevent it from striking firing pin when hammer is manually cocked and thumb could slip.
- Locking safety, i. e. it prevents firing of the pistol until the barrel and the slide are in their fully closed firing position.
- c) Safety indicators External hammer easily seen or felt by touch to tell when the hammer is cocked and the pistol ready for action.
- Live round indicator. When the slide is in its closed position on a chambered cartridge, the front end of the extractor emerges and shows a red dot on its upper surface, thus warning that the pistol is loaded.

BALLISTICS:

Caliber:

Initial velocity (Vo)	340/380 m.p.s. = 1,016/1,247 f.p.s.
Muzzle velocity (Eo)	45/55 kpm = 326/398 ft. lb.
Test pressure at chamber	3,000 kp/cm ² = 42,660 p.s.i
Effective range	50 meters = 164 ft.
Penetration in pine boards at 50 meters	10 cm = 3.94 in.

TRIGGER PULLS:

Length of pull measured from center of pull:

With hammer cocked (SINGLE ACTION):

1st cycle 2.50 mm = 0.098 in.

2nd cycle 2.50 mm = 0.098 in.

With hammer uncocked (DOUBLE ACTION)

12.00 mm = ... 0.472 in.

Weight of pulls:

With hammer cocked (SINGLE ACTION) 2,000 grams = 4.41 lb.

With hammer uncocked (DOUBLE ACTION) 3,600 grams = 7.94 lb.

DIMENSIONS AND WEIGHT OF PISTOL

Overall length	193 mm = 7.60 in.
Height	135 mm = 5.32 in.
Width of pistol	33 mm = 1.30 in.
Length of barrel	98 mm = 3.86 in.
Length of sighting line	148 mm = 5.83 in.
Front sight width	3.00 mm = 0.118 in.
Rear sight notch width	3.50 mm = 0.138 in.
Weight of pistol with empty magazine	860 grams = 30.36 oz.
Magazine capacity:	15 rounds

COMPONENT PARTS OF "STAR" MOD. 30 PK CAL. 9 MM. PARABELLUM PISTOL

Part No.	Nomenclature	Part No.	Nomenclature
30PK0101	Frame.	300837	Ambidextrous thumb safety retaining plunger.
300101/01	Backstrap.	28A0837/01	Ambidextrous thumb safety retaining plunger spring.
28P0102	Hammer lock sliding way.	300838	Ambidextrous thumb safety positioning plunger.
28P0102/01	Hammer lock sliding way retaining pin.	280941	Slide stop.
300203	Ejector.	280942	Slide stop plunger.
280204	Backstrap retaining plunger.	280943	Slide stop plunger spring.
300204/01	Ejector pin.	280945	Slide stop plunger elastic retaining pin.
300204/02	Ejector friction plunger.	281153	Magazine tube.
300204/03	Ejector friction plunger spring.	281154	Magazine follower.
280205	Backstrap retaining plunger spring.	281156	Magazine follower spring.
280205/01	Backstrap retaining plunger pin.	281157	Magazine floor plate.
280306	Hammer.	281158	Magazine floor plate catch.
280307	Hammer bar.	30P1261	Barrel.
280308	Hammer pins.	30P1365	Slide.
280309	Hammer spring.	301365/01	Plungers housing plug.
280310	Hammer spring support.	301366	Extractor.
280311	Hammer axis.	301368	Extractor plunger.
280312	Hammer lock.	301369	Extractor plunger spring.
280414	Sear.	301370	Firing pin.
280415	Sear axis.	301371	Firing pin retainer.
300416	Sear spring.	281372	Firing pin spring.
280519	Trigger.	281374	Rear sight.
280520	Trigger pin.	281375	Rear sight windage spindle.
280521	Trigger spring.	281376	Rear sight base.
280523	Trigger bar.	281377/01	Rear sight windage spindle spring.
280524	Trigger bar pin.	281377/02	Rear sight windage spindle retaining pin.
280525	Interruptor.	30P1481	Recoil spring guide.
280628	Magazine catch.	30P1481/02	Recoil spring guide coupling.
280629	Magazine catch lock.	301481/04	Recoil spring guide coupling locking pin.
280630	Magazine catch lock spring.	281482	Recoil spring guide washer.
280732	Magazine safety.	28P1483	Recoil spring.
300836	Ambidextrous thumb safety.	281895	Grip, right.
300836/01	Ambidextrous thumb safety wing, right.	281896	Grip, left.



OPERATING AND DISASSEMBLY
INSTRUCTIONS FOR
"STAR" MOD. 30 PK CAL. 9 MM. PARABELLUM PISTOL

Thumb safety in
ON position.

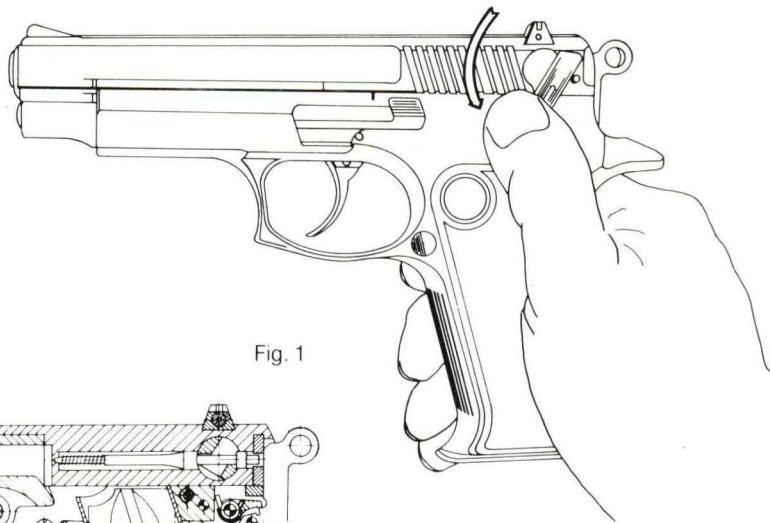
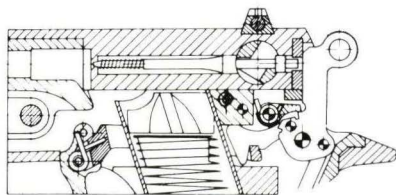

Fig. 1



To put thumb safety ON. (Fig. 1)

When handling the pistol, always put the ambidextrous thumb safety, located on both left and right side of the slide, in ON position, i. e. push it downward until left thumb safety wing rear end conceals the red dot on the left rear side of the slide. Through this action, the firing pin is forced in and remains locked inside the slide, away from the hammer, and the pistol may thus be safely carried and handled and an accidental discharge of an eventual chambered cartridge prevented, even if the trigger is pulled.

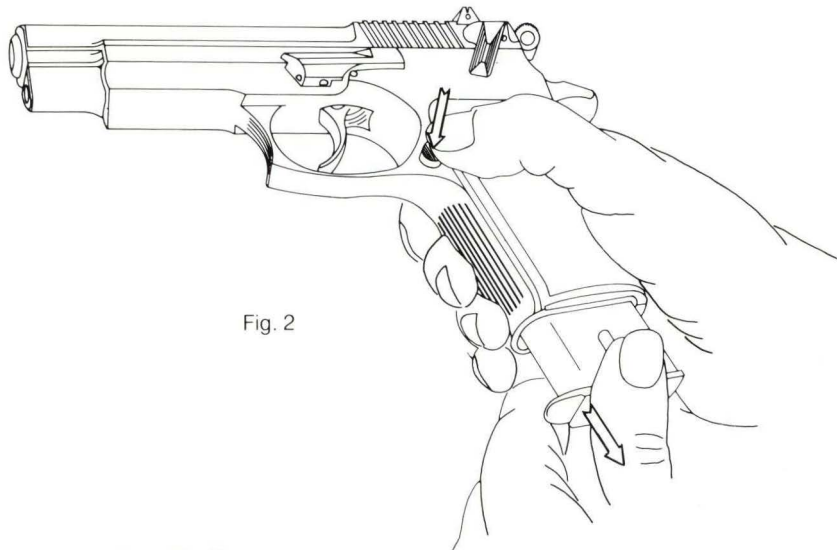
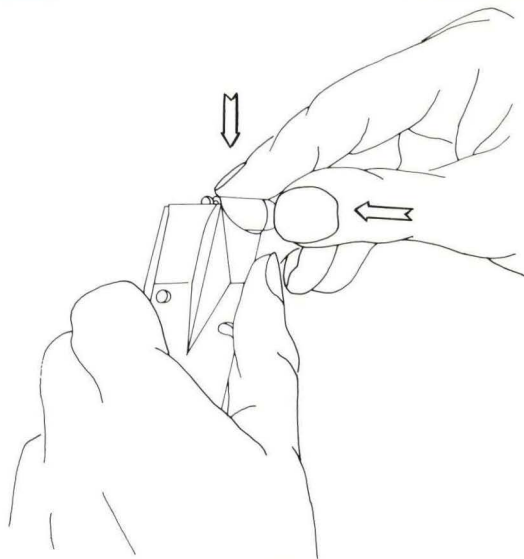

Fig. 2

To remove the magazine. (Fig. 2)

With the safety in ON position (red dot concealed), depress the magazine catch button, located on the left side of the frame, just back the trigger guard, and withdraw the magazine from the grip by hand, or let it fall freely onto the palm of your free hand.

With the magazine removed, the pistol is now double safe because of the action of the magazine safety which permits the trigger bar to disengage from the sear. Once the magazine is again inserted, the magazine pushes the magazine safety upward to free the trigger bar and permit its engagement with the sear.



To fill the magazine. (Fig. 3)

Holding the magazine in the left hand, take a cartridge grasping it between the thumb and index finger of the right hand, place the cartridge head on the front end of the magazine follower and push it slightly down until it can be slid in under the lips of the magazine wall. Another cartridge is then placed on top of the first one and forced down and slid in. This procedure is used until the magazine contains whatever cartridges are to be fired. (It will take up to 15 rounds). The holes on the right side of the magazine permit checking the number of cartridge loaded.

When inserting the cartridges, take care not to force them against the magazine lips in order to prevent damage to the latter, which would cause a malfunctioning of the pistol. Always insert them gently under the lips of the magazine wall.

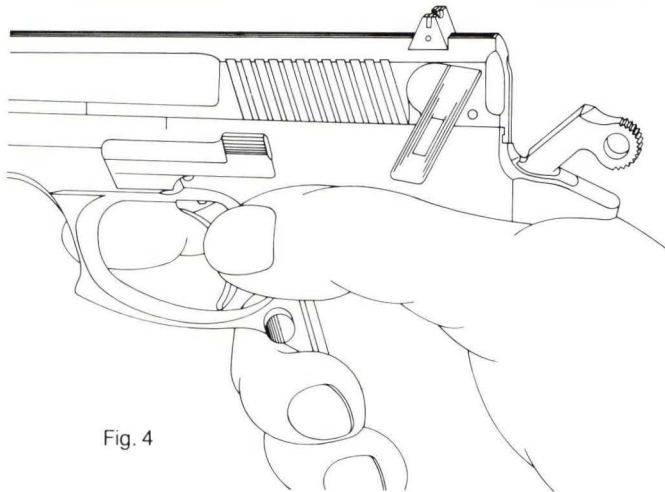

Fig. 4

To load the pistol. (Fig. 4)

Hold the pistol in the shooting hand and with the free hand insert the loaded magazine in its housing in the grip, until it is held in place by the magazine catch.

Be certain that the thumb safety is in its ON position and grasping the slide between thumb and index finger of the left hand at the rear serrations, pull it back fully and allow the slide to snap forward forced by the recoil spring. The slide will in its forward motion extract the first cartridge from between the magazine lips and chamber it, at which moment the extractor will emerge and warn by a red dot or by touch that the pistol is loaded.

The pistol is then in a loaded, cocked and safe condition and an optional uncocking is achieved by pulling the trigger, being always certain that the thumb safety is in the ON position before pulling.

To fire the pistol with cocked hammer (Single action)

With a cartridge already chambered and the hammer cocked, hold the pistol in the shooting hand with the thumb of the free hand, or that of the shooting hand, push the thumb safety upward (red dot visible and white dot concealed see Fig. 5). This action will free the retracted firing pin and its rear end will now protrude again through the hole of its housing.

Squeeze the trigger and the sear will free the hammer to move forward and strike the firing pin, which in turn will strike and fire the cartridge in the chamber. The discharge of the fired cartridge forces then the slide backwards extracting the fired cartridge case and cocking the hammer again. The subsequent forward movement of the slide, under the pressure of the recoil spring, strips another cartridge from between the magazine lips into the chamber. The pistol is then ready to fire again. This is repeated as rapidly as the trigger is pressed, until the magazine is empty.

To fire the pistol with uncocked hammer (Double Action)

As under «Single Action», the first cartridge must be manually chambered. This done, with the safety always in ON position, squeeze the trigger and the hammer will move forward against the rear of the slide, but as the firing pin has been retracted by the thumb safety, it will not be able to strike it.

To fire, disengage the thumb safety and the pistol will then be ready for firing under double action. Pull the trigger all the way back and the hammer will be raised until it reaches its rearmost position; it will then come forward and strike the firing pin to fire the chambered cartridge.

All further shooting sequences are performed as under «Single Action».

Thumb safety in
OFF position.

Fig. 5

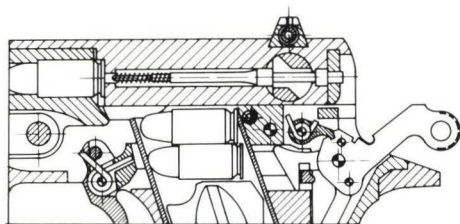

Last shot.

When the last round in the magazine has been fired, the left front side of the magazine follower pushes against a projection on the inside of the slide stop. The slide stop moves then upward and engages in a notch in the slide (see Fig. 6), thus holding the slide open, serving as an indicator that the emptied magazine must be replaced by a loaded one.

If the firing should be resumed, first engage the safety in its ON position, remove the emptied magazine and replace it by a loaded one. Release the slide by pressing upon the thumb piece of the slide stop and the return movement of the slide under the influence of the recoil spring forces a cartridge into the chamber leaving the pistol again ready for firing.

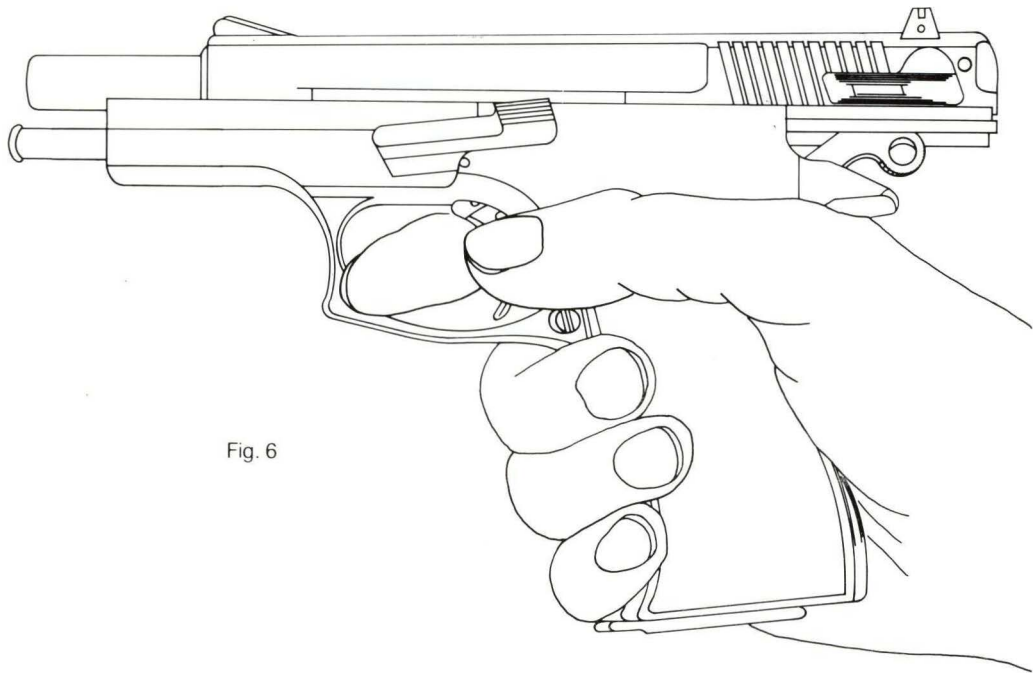

Fig. 6

TO DISASSEMBLE THE PISTOL FOR CLEANING PURPOSES.

1. First of all, engage the thumb safety in its ON position (red dot concealed and white dot exposed) (see fig. 1).
2. Remove the magazine and check to ensure that there is no cartridge left in the chamber and extract it if it is (see fig. 2).
3. Cock the hammer by hand and pull the slide back until reference line on the left side of the slide is in line with a corresponding line on the frame, at the same time press the index finger of the right hand against the end of the slide stop shaft protruding from the opposite side of the frame above the trigger guard, until the slide stop is partially extracted. With the thumb and index finger of the left hand grasp the slide stop and pull it out, at which moment the slide will snap forward on its guide (see fig. 7).
4. The slide assembly may then be drawn forward and removed from the frame (see fig. 8).
5. Remove recoil spring assembly by pulling its rear end out from between the barrel lugs (see fig. 9).
6. The barrel may now be withdrawn by lifting it out from the rear of the slide (see fig. 10).

NO FURTHER DISMOUNTING IS NECESSARY TO PROPERLY CLEAN THE PISTOL

Cleaning: Clean the barrel and chamber after firing. Built up residue in the chamber can result in misfires due to the cartridge not seating fully in the chamber. Avoid cleaning from the muzzle.

Under normal using conditions it is advisable to put a little oil on the friction points. Use nothing but thin gun oil. Always wipe off the exterior of the gun after use with a slightly oiled cloth. This will remove finger marks and protect the finish.

However, in dusty or sandy environments it is preferable to keep the pistol as dry as possible, with a minimum of lubrication, as otherwise the dust and sand could hang on and impair the good effects of the lubrication.

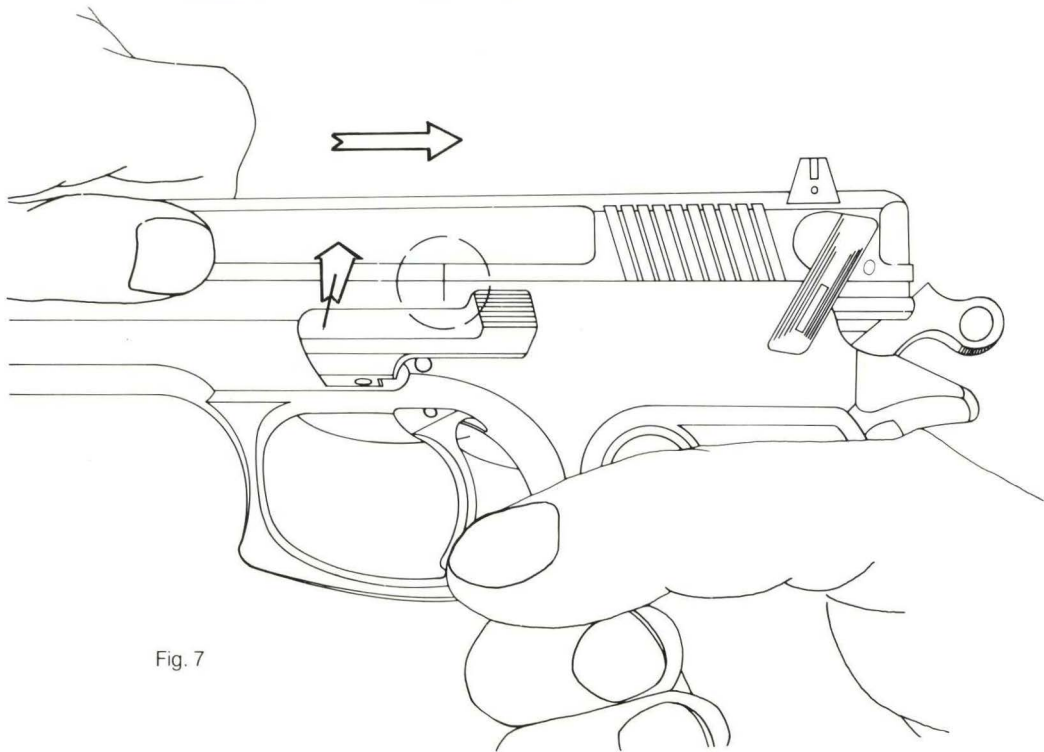

Fig. 7

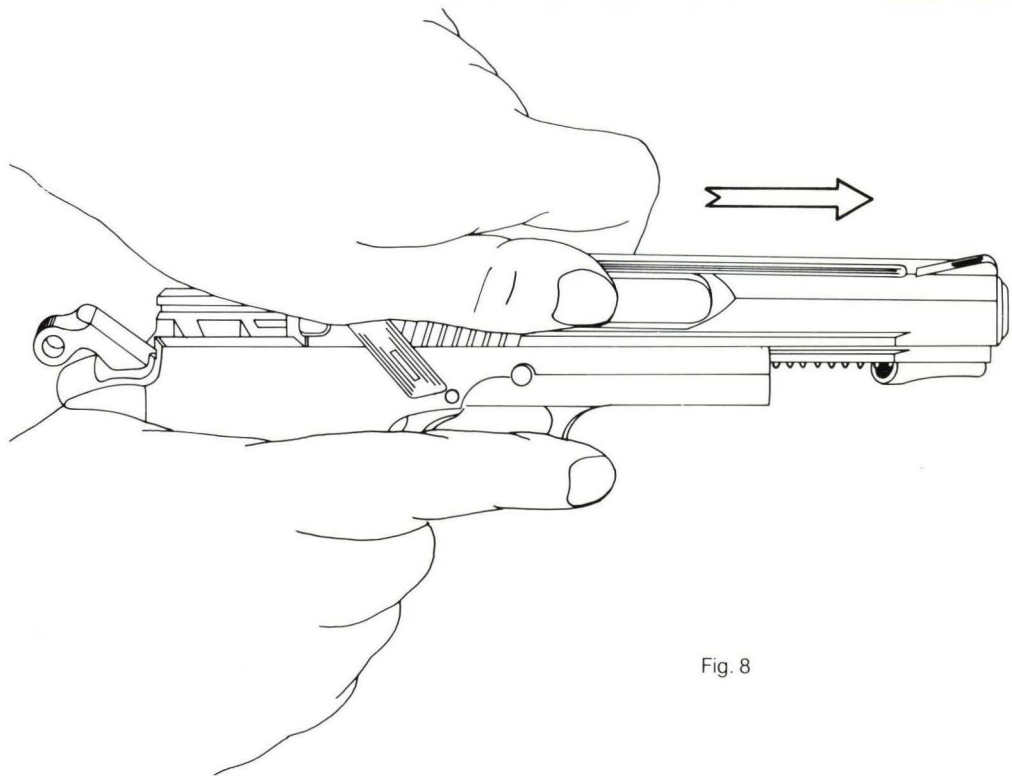

Fig. 8

Fig. 9

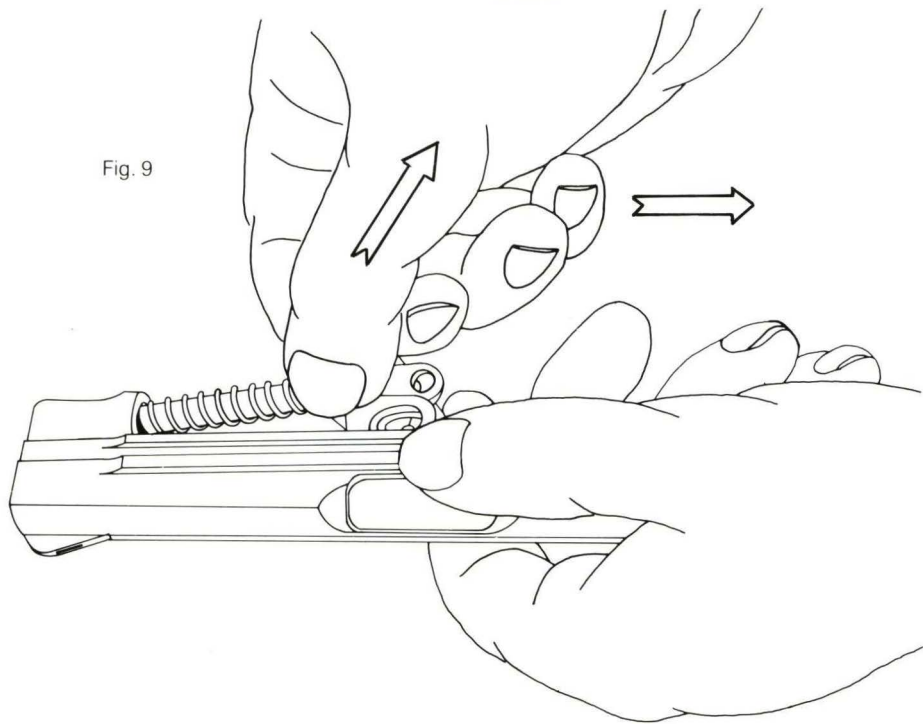
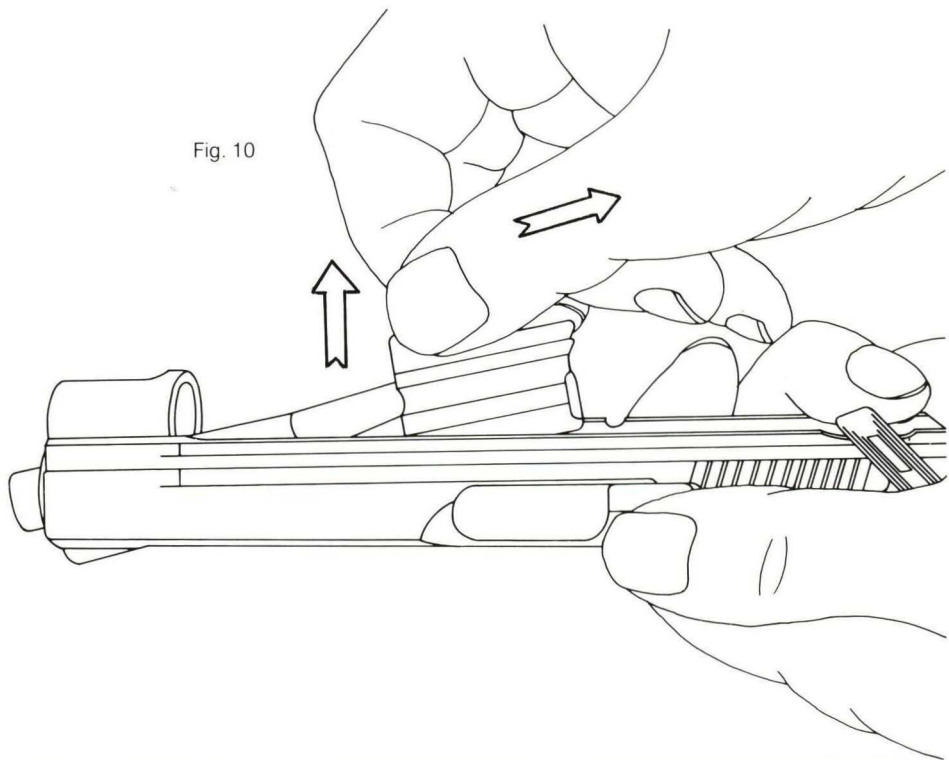

Fig. 10



COMPLETE DISASSEMBLY.

Commence as under disassembly for cleaning purposes and proceed then as follows:

Slide stop assembly: Drive out the elastic retaining plunger pin (280945) to free the plunger (280942) and its spring (280943) and remove them.

Frame group: Insert an empty magazine in its housing to lower the hammer by hand (do not snap it) and remove magazine once more.

Push the backstrap retaining plunger (280204) - seen through the hole bored in the lower rear end of the backstrap - with the slide stop shaft inward and simultaneously slightly shift the backstrap (which contains the ejector, hammer, interruptor, sear, hammer spring and attendant parts) until the plunger remains depressed (see fig. 11).

Grasp the hammer between the thumb and index finger and lift the backstrap from the frame (see fig. 12). The removal of the backstrap also frees both grips, which may be lifted off the frame.

It may be that the press fit of the grips gives rise to have the backstrap somehow wedged, as it has to hold the grips firmly in place, making it difficult to remove it as explained. In such a case, slightly strike on the slide stop with the plastic handle of the cleaning rod and alternately on the lower end of the backstrap (see fig. 11a & 11b).

Drive out the trigger pin (280520) - overcoming the resistance of the trigger spring - which also acts as a retainer of the magazine safety (280732), and remove magazine safety. The trigger-bar assembly may then be lifted off the frame as a unit.

Strip the trigger-bar assembly by drifting out their pin (280524) and the trigger spring (280521) will also be freed.

To remove the sliding way (28P0102) of the hammer lock (280312), drive out its transversal retaining pin (28P0102/01).

The backstrap retaining plunger (280204) and its spring (280205) are released and removed by drifting out the elastic pin (280205/01).

Backstrap.

Extract hammer spring support (280310) and drift out the hammer axis (280311) and sear/interruptor axis (280415); all other attendant parts of the percussion mechanism will so be released for removal.

This disassembly sequence should be followed to properly release the aforementioned parts.

Drift out the ejector pin (300204/01) to free the ejector (300203), its plunger (300204/02) and spring (300204/03).

Magazine catch.

Depress the magazine catch (280628) and with a small screwdriver turn the magazine catch lock (280629), which is seen at the right side of the frame, one-quarter of a turn clockwise, thus to disengage it from its locking slot in the frame. The magazine catch with its lock and spring may now be removed as an assembly.

The magazine catch assembly may now be stripped by turning its lock one-quarter of a turn counter-clockwise. Take care not to let the lock and spring to jump away when released.

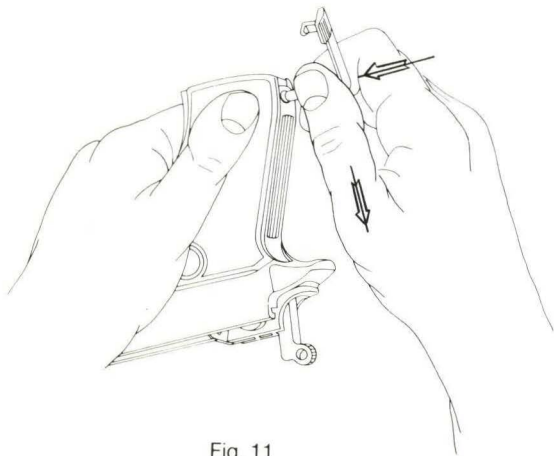

Fig. 11

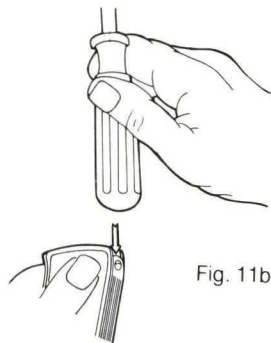

Fig. 11b

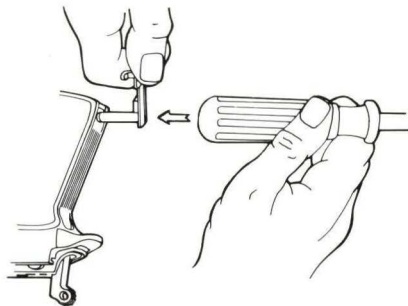

Fig. 11a

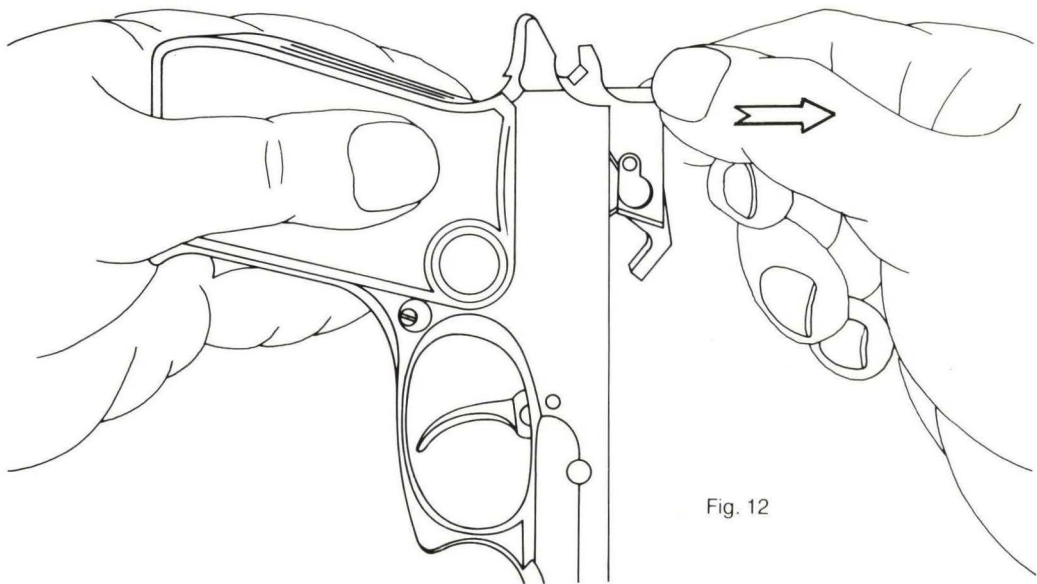

Fig. 12

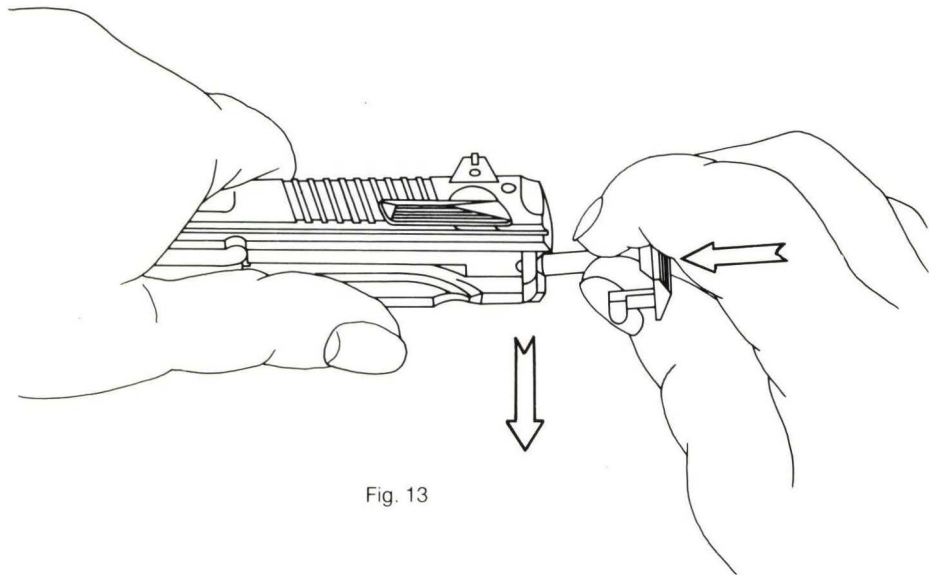

Fig. 13

Slide.

Place the thumb safety in upper position and using the slide stop shaft point, push the firing pin (301370) forward until it clears its retainer (301371) and withdraw the retainer downward from its seat. The firing pin with its spring (281372), as well as the plug (301365/01) may now be removed.

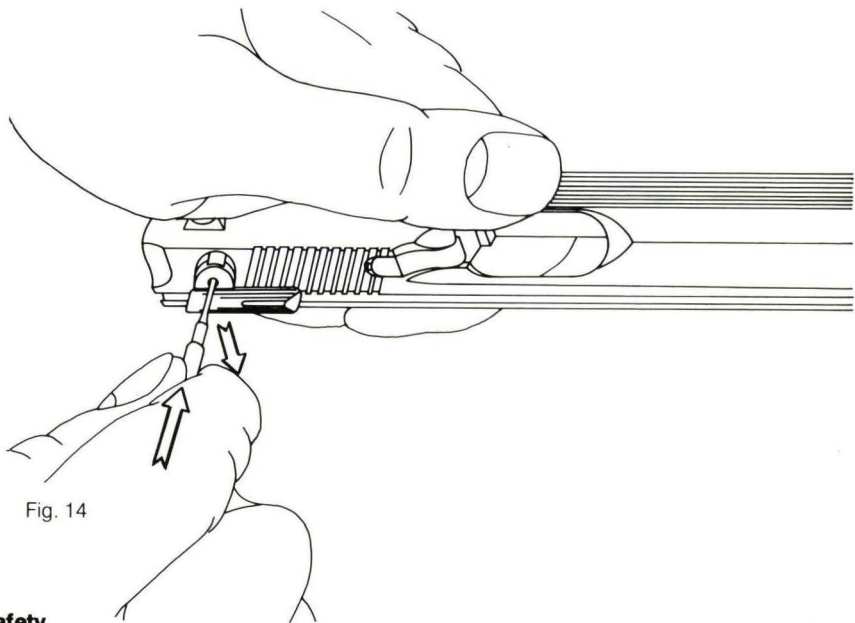

Fig. 14

Thumb safety.

Insert the firing pin point through the hole in the center of the right thumb safety wing (300836/01) to depress its retaining plunger (300837), simultaneously pushing the wing downward from its seat, being careful not to lose the plunger and its spring (28A0837/01) which are small and under pressure. Withdraw these parts. Move then the left thumb safety wing (300836) to a point midway the upper and lower positions and withdraw it from the slide by driving out its shaft.

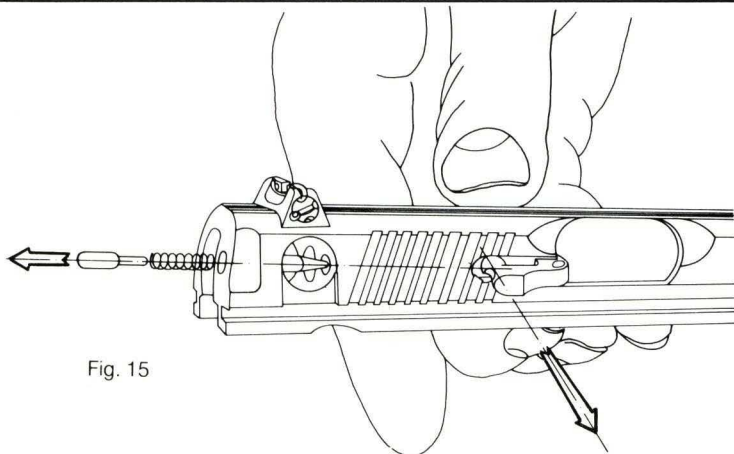

Fig. 15

Extractor.

Once the thumb safety has been removed, its positioning plunger (300838) and the extractor plunger (301368) with their spring (301369) will freely slide out by slightly striking the rear end of the slide vertically on a piece of wood. This action will also free the extractor for removal (see fig. 15).

Rear sight assembly.

May be removed by tapping it out from its dovetail using a suitable brass punch from left to right. Drive out the spindle retaining pin (281377/02) to release all the other attendant parts.

Recoil spring assembly.

Retract the rear end of the recoil spring (28P1483) until it clears the exit hole of the recoil spring guide coupling locking pin (301481/04) and using the firing pin, drive out the pin and unscrew the coupling (30P1481/02).

Note: Care should be taken not to let the spring jump away when released by grasping it while releasing its tension.

Magazine.

Insert the slide stop shaft point through the hole in the floor plate to release the floor plate catch; slide floor plate forward and free from the magazine tube, permitting the withdrawal of the floor plate catch, magazine spring and follower. Care should be taken not to let floor plate catch and spring jump away when released.

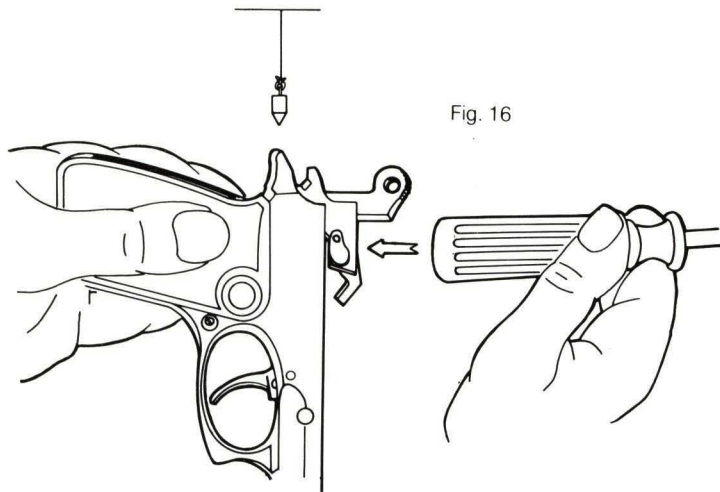

Fig. 16

REASSEMBLY OF THE PISTOL.

Reassembly of the parts is in general easily accomplished by reversing the aforementioned procedures for disassembly

Special attention should be paid when inserting the backstrap, i. e. with the frame always pointing downward, the hammer lowered and the grips replaced in their correct position, push backstrap inward to enable the hammer lock to enter into the notch on the rear end of the trigger bar. While depressing the retaining plunger, push the backstrap further in until it engages the retaining plunger. If necessary, strike with the plastic handle of the cleaning rod against the upper flat - just in front of the hammer - to facilitate this engagement (see fig. 16).

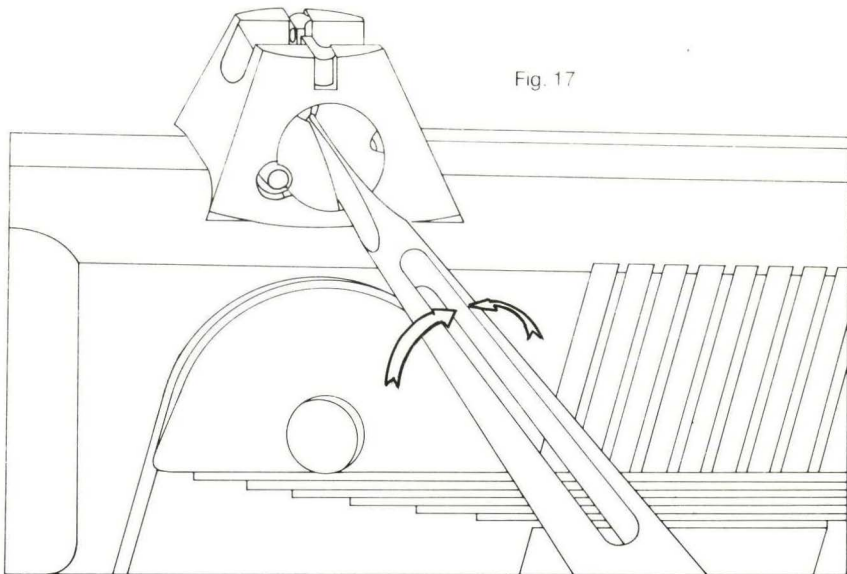

Fig. 17

Rear sight adjustment.

This pistol is provided with a click rear sight, adjustable for windage. Rotate the windage adjusting spindle (281375), using the small screwdriver packed with the pistol, in the desired direction. Each click shifts the rear sight notch 0.125 mm. to either side.

STAR BONIFACIO ECHEVERRIA S. A.

CONTRACTORS TO:

THE SPANISH AIR FORCE, ARMY, NAVY, BODY OF RURAL POLICE,
LAW ENFORCEMENT AGENCIES AND NATIONAL POLICE.

C/TORREKUA, 3 - P. O. BOX 10
TELF. (943) 71 73 40
TELEX 36091 BEIA E - TELEGRAF. «STAR»
EIBAR (GUIPUZCOA) ESPAÑA

